

Fig. 2 Fixed Output Voltage Step-Down DC/DC Converter

ORDERING INFORMATION

AIC2359-XXXXXX

- PACKING TYPE
TR: TAPE & REEL
BG: BAG
- PACKAGE TYPE
DF: DFN-12 (3x3x0.75-0.45)
- G: Green Package
- Output Voltage: Vout1/Vout2
Default Adjustable
ZK: 3.3V/1.8V
ZE: 3.3V/1.2V
RK: 2.5V/1.8V

Example: AIC2359GDFTR

- in DFN-12 (3x3x0.75-0.45) Green
Package and Tape & Reel Packing Type
- AIC2359-ZKGFTR
→ 3.3V/1.8V Vout Version
in DFN-12 (3x3x0.75-0.45) Green
Package and Tape & Reel Packing Type

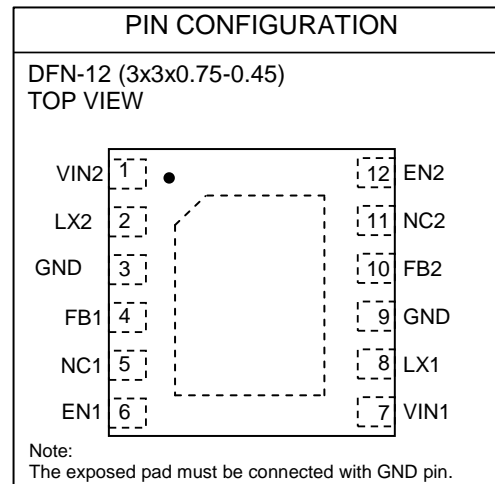

■ ABSOLUTE MAXIMUM RATINGS

Supply Input Voltage, V_{IN1} , V_{IN2}	6.0V
Pin Voltage for all other Pins	-0.3V to V_{IN}
Operating Ambient Temperature Range T_A	-40°C to 85°C
Operating Maximum Junction Temperature T_J	150°C
Storage Temperature Range T_{STG}	-65°C to 150°C
Lead Temperature (Soldering 10 Sec.).....	260°C
Thermal Resistance Junction to Case DFN-12 (3x3x0.75-0.45)*	20°C/W
Thermal Resistance Junction to Ambient DFN-12 (3x3x0.75-0.45)*	50°C/W

(Assume no Ambient Airflow)

Absolute Maximum Ratings are those values beyond which the life of a device may be impaired.

*The package is placed on a two layers PCB with 2 ounces copper and 2 square inch, connected by 8 vias.

ELECTRICAL CHARACTERISTICS

 ($V_{IN}=3.6V$, $V_{OUT}=2.5V$, unless otherwise specified. Typical values are at $T_A=25^{\circ}C$)

PARAMETER	SYMBOL	CONDITIONS	MIN	TYP	MAX	UNITS
Input Voltage Range	V_{IN}		2.2		5.5	V
Reference Voltage	V_{REF}		0.588	0.6	0.612	V
FB Input Current	I_{FB}	$V_{FB} = 0.62V$	-50		50	nA
Quiescent Current	I_Q	$I_{OUT} = 0mA$, $V_{FB} = V_{REF} + 5\%$		65	85	μA
Shutdown Supply Current	I_{SHDN}			0.1	1	μA
Enable High Input Voltage	V_{EN_H}		1.5		V_{IN}	V
Enable Low Input Voltage	V_{EN_L}				0.4	V
Output Adjustment Range	V_{OUT}	$(\Delta V = I_{OUT} \times P_{RDS(ON)})$	V_{REF}		$V_{IN} - \Delta V$	V
Output Voltage Accuracy	ΔV_{OUT}		-3	V_{OUT}	3	%
P-Channel On-Resistance	$P_{RDS(ON)}$	$I_{OUT}=200mA$		0.28	0.39	Ω
N-Channel On-Resistance	$N_{RDS(ON)}$	$I_{OUT}=200mA$		0.25	0.39	Ω
P-Channel Current-Limit Threshold			1.3	1.6		A
Oscillator Frequency	f_{OSC}	$I_{OUT}=100mA$	1.2	1.5	1.8	MHz
Maximum Duty Cycle	$duty_{MAX}$		100			%
Thermal Shutdown Temperature	T_{SD}			150		$^{\circ}C$
LX Leakage Current	I_{LX}	$V_{LX}=0V$ or $V_{LX}=3.6V$	-1		1	μA

■ TYPICAL PERFORMANCE CHARACTERISTICS

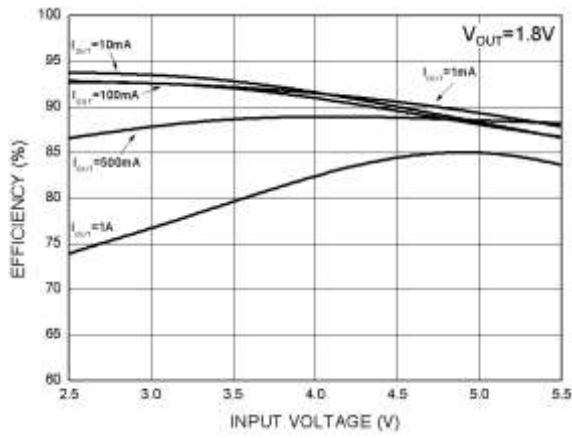

Fig. 3 Efficiency vs. Input Voltage

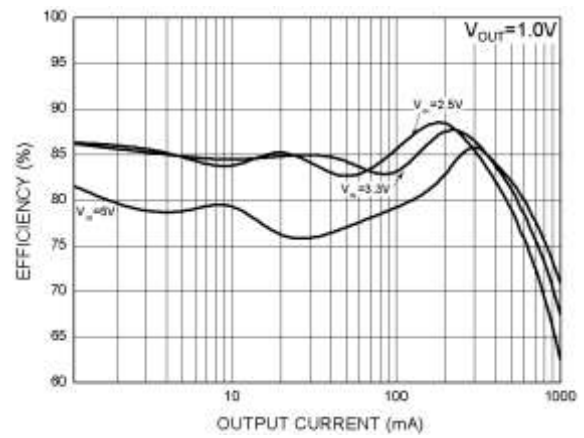

Fig. 4 Efficiency vs. Output Current

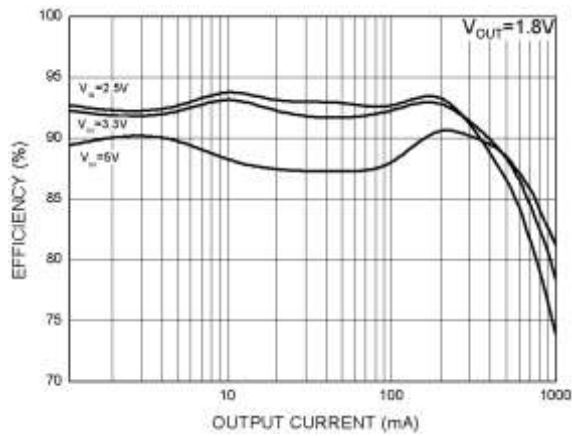

Fig. 5 Efficiency vs. Output Current

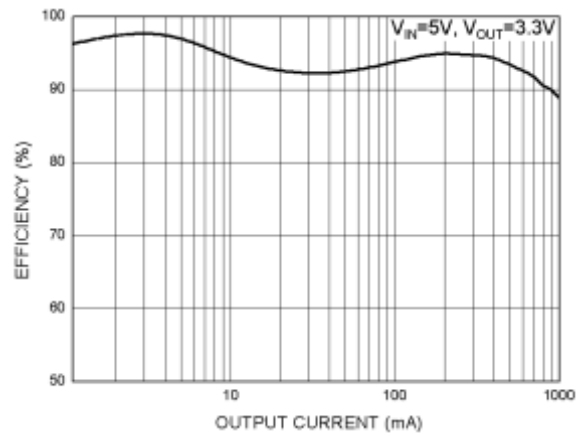

Fig. 6 Efficiency vs. Output Current

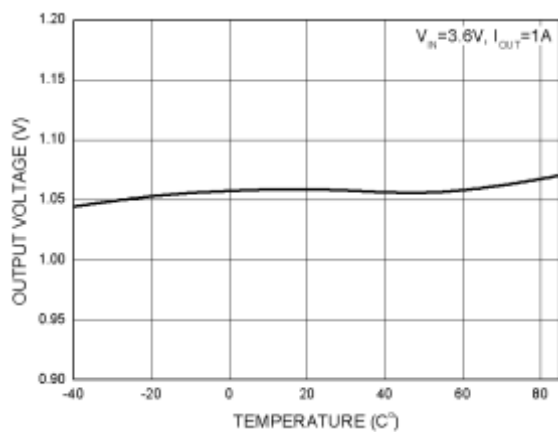

Fig. 7 Output Voltage vs. Temperature

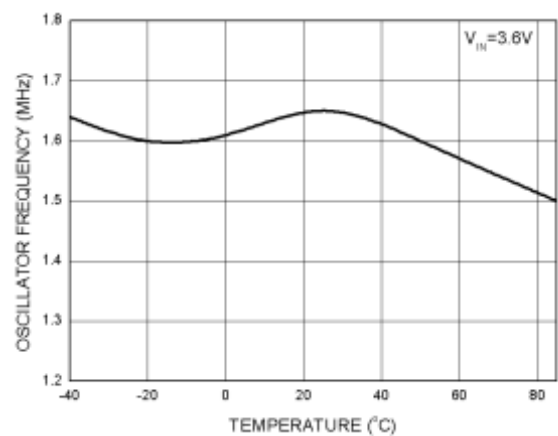

Fig. 8 Oscillator Frequency vs. Temperature

■ TYPICAL PERFORMANCE CHARACTERISTICS (Continued)

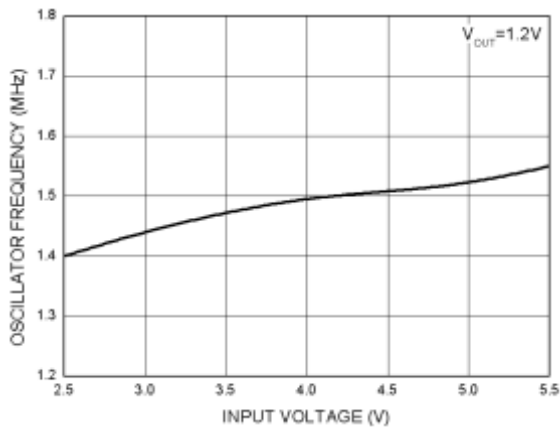

Fig. 9 Oscillator Frequency vs. Input Voltage

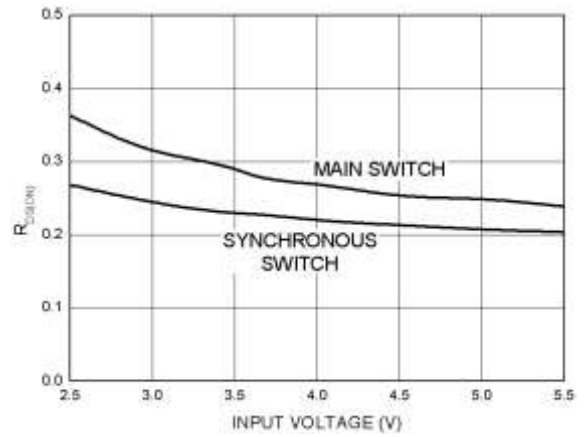

Fig. 10 $R_{DS(ON)}$ vs. Input Voltage

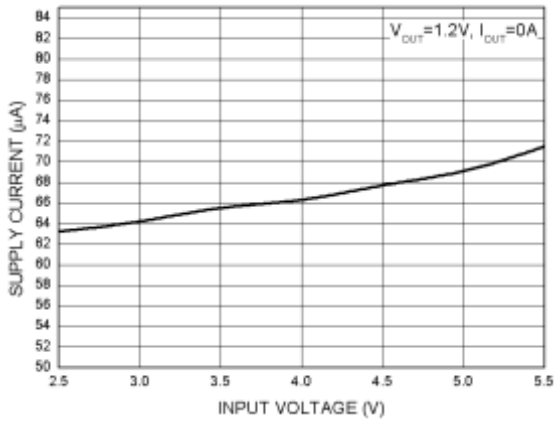

Fig. 11 Supply Current vs. Input Voltage

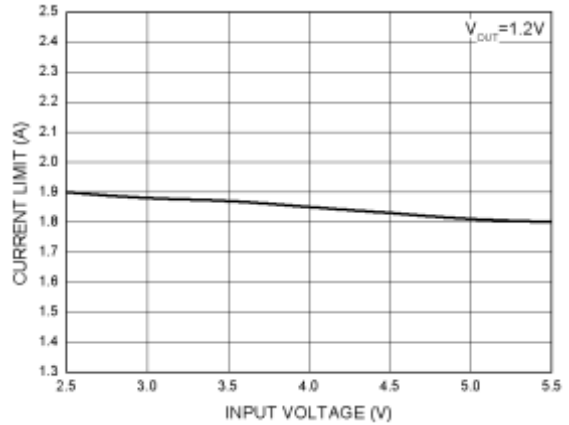

Fig. 12 Current Limit vs. Input Voltage

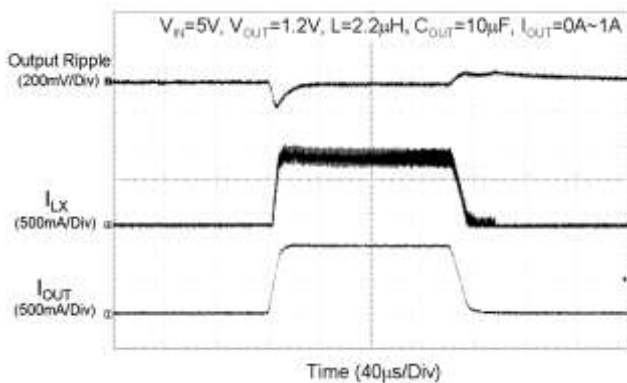

Fig. 13 Load Transient Response

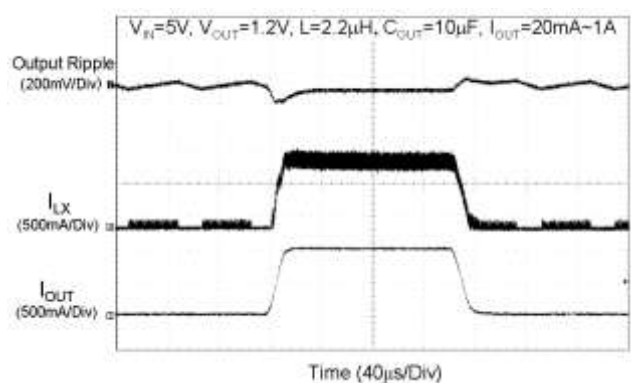

Fig. 14 Load Transient Response

■ TYPICAL PERFORMANCE CHARACTERISTICS (Continued)

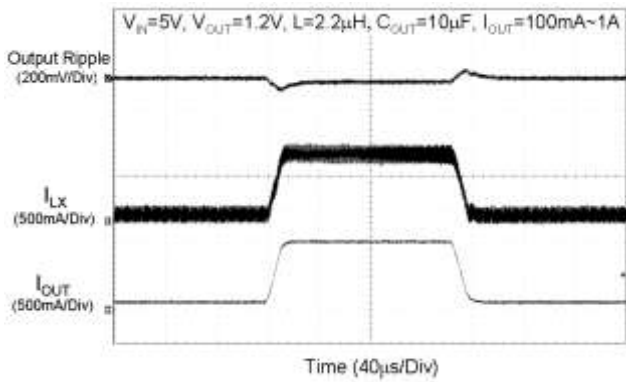

Fig. 15 Load Transient Response

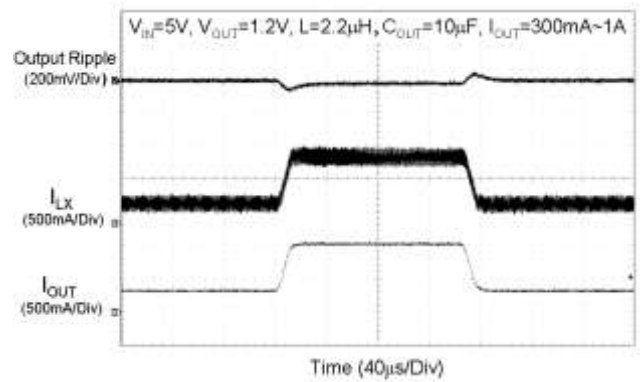

Fig. 16 Load Transient Response

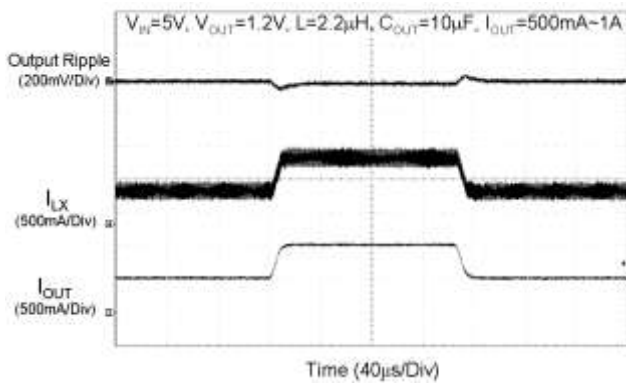

Fig. 17 Load Transient Response

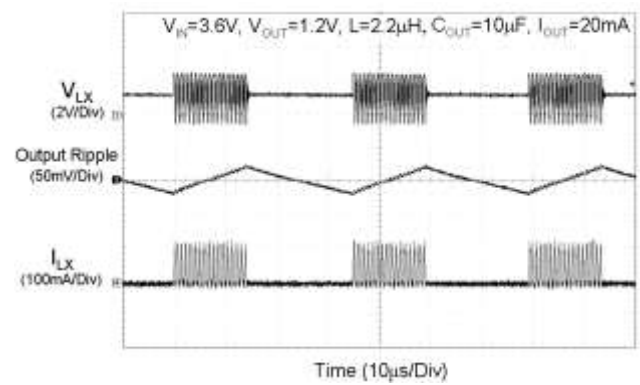
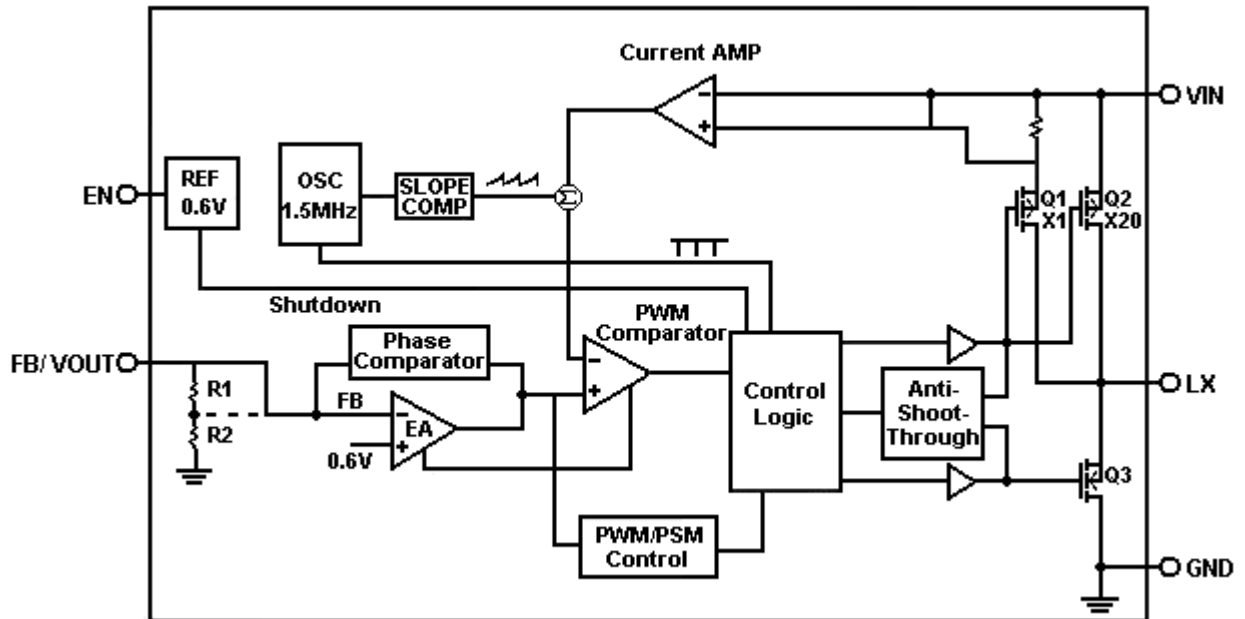

Fig. 18 PSM Operation

■ BLOCK DIAGRAM

■ PIN DESCRIPTIONS

Pin Number	Pin Name	Pin Function
1	VIN2	Power Input of Channel 2.
2	LX2	Pin for Switching of Channel 2.
3, 9, Exposed Pad (13)	GND	Ground. The exposed pad must be soldered to a large PCB and connected to GND for maximum power dissipation.
4	FB1	Feedback of Channel 1.
5, 11	NC1, NC2	No Connection or Connect to VIN.
6	EN1	Chip Enable of Channel 1 (Active High). $V_{EN1} \leq V_{IN1}$.
7	VIN1	Power Input of Channel 1.
8	LX1	Pin for Switching of Channel 1.
10	FB2	Feedback of Channel 2.
12	EN2	Chip Enable of Channel 2 (Active High). $V_{EN2} \leq V_{IN2}$.

■ APPLICATION INFORMATION

Operation

The AIC2359 is a low-noise step-down DC/DC converter with current-mode PWM/PSM control architecture. It features an internal synchronous rectifier, which eliminates the external Schottky diode and increases efficiency. During normal operation, the AIC2359 can regulate its output voltage through a feedback control circuit, which is composed of an error amplifier; a current comparator and several control signal generators. By comparing the feedback voltage to the reference voltage of 0.6V, the error amplifier varies its output voltage. The output voltage of the error amplifier is compared with the summing signal of current sensing signal and slope compensation signal to determine the duty cycle of internal main power switch (P-channel MOSFET). While the main power switch is turned on, the synchronous power switch (N-channel MOSFET) will be turned off through anti-short-through block. Similarly, when the main power switch is turned off, the synchronous power switch will be turned on until the inductor current starts to reverse or the beginning of the next switching cycle. In order to achieve better efficiency and prevent overcharging the output capacitor, AIC2359 will enter pulse-skipping-modulated mode (PSM) operation while working at light load conditions.

Current Limitation

The AIC2359 provides current limit function by using an internal sensing resistor. When the main power switch turns on, current follows through the internal sensing resistor. And current amplifier senses the voltage, which crosses the resistor, and amplifies it. While the sensed voltage gets higher than reference voltage, the current limitation function is activated. While the current limitation function is activated, the duty cycle will be reduced to limit the output power to protect the internal power switches.

Short Circuit Protection

While the output is shorted to ground, the switching

frequency of AIC2359 will be reduced to one third of the normal switching frequency. This lower switching frequency ensures the inductor current has more time to discharge, thereby preventing inductor current runaway. The switching frequency will automatically return to its designed value while short circuit condition is released.

Shutdown

By connecting the EN pin to GND, the AIC2359 can be shut down to reduce the supply current to 0.1 A (typical). At this operation mode, the output voltage of step-down converter is equal to 0V.

100% Duty Cycle Operation

When the input voltage approaches the output voltage, the AIC2359 smoothly transits to 100% duty cycle operation. This allows AIC2359 to regulate the output voltage until AIC2359 completely enters 100% duty cycle operation. In 100% duty cycle mode, the output voltage is equal to the input voltage minus the voltage, which is the drop across the main power switch.

The AIC2359 achieves 100% duty cycle operation by extending the turn-on time of the main power switch. If the summing signal of current sensing signal and slope compensation signal does not reach the output voltage level of the error amplifier at the end of 90% switching period, the main power switch is continuously turned on and the oscillator remains off until the summing signal of current sensing signal and slope compensation signal reaches the output voltage level of the error amplifier. After the summing signal of current sensing signal and slope compensation signal reaches the output voltage level of the error amplifier,

the main power switch is turned off and the synchronous power switch is turned on for a constant off time. At the end of the constant off time, the next switching cycle is begun. While the input voltage approaches the output voltage, the switching frequency decreases gradually to smoothly transit to 100% duty cycle operation.

If input voltage is very close to output voltage, the

switching mode goes from pure PWM mode to 100% duty cycle operation. During this transient state mentioned above, large output ripple voltage may appear on output terminal.

Components Selection

Inductor

The inductor selection depends on the current ripple of inductor, the input voltage and the output voltage.

$$L \geq \frac{V_{OUT}}{f_{OSC} \cdot \Delta I_L} \left(1 - \frac{V_{OUT}}{V_{IN}} \right)$$

Accepting a large current ripple of inductor allows the use of a smaller inductance. However, higher current ripple of inductor can cause higher output ripple voltage and large core loss. By setting an acceptable current ripple of inductor, a suitable inductance can be obtained from above equation. A 2.2μH inductor is recommended for most AIC2359 applications.

In addition, it is important to ensure the inductor saturation current exceeds the peak value of inductor current in application to prevent core saturation. The peak value of inductor current can be calculated according to the following equation.

$$I_{PEAK} = I_{OUT(max)} + \frac{V_{OUT}}{2 \times f_{OSC} \cdot L} \left(1 - \frac{V_{OUT}}{V_{IN}} \right)$$

Input Capacitor and Output Capacitor

To prevent the high input voltage ripple and noise resulted from high frequency switching, the use of low ESR ceramic capacitor for the maximum RMS current is recommended. The approximated RMS current of the input capacitor can be calculated according to the following equation.

$$I_{CINRMS} \approx \sqrt{I_{OUT(MAX)}^2 \times \frac{V_{OUT}(V_{IN} - V_{OUT})}{V_{IN}^2} + \frac{\Delta I_L^2}{12}}$$

The selection of output capacitor depends on the required output voltage ripple. The output voltage ripple can be expressed as:

$$\Delta V_{OUT} = \frac{\Delta I_L}{8 \times f_{OSC} \cdot C_{OUT}} + ESR \cdot \Delta I_L$$

For lower output voltage ripple, the use of low ESR ceramic capacitor is recommended. The tantalum capacitor can also be used well, but its ERS is larger than that of ceramic capacitor.

When choosing the input and output ceramic capacitors, X5R and X7R types are recommended because they retain their capacitance over wider ranges of voltage and temperature than other types.

Output Voltage Programming (AIC2359 Adjustable Version Only)

By connecting a resistive divider R_{11} and R_{12} (R_{21} and R_{22}), the output voltage of AIC2359 step-down converter can be set. V_{OUT1} and V_{OUT2} can be calculated as:

$$V_{OUT1} = 0.6 \times \left(1 + \frac{R_{11}}{R_{12}} \right)$$

$$V_{OUT2} = 0.6 \times \left(1 + \frac{R_{21}}{R_{22}} \right)$$

The resistive divider should sit as close to VFB pin as possible.

Layout Consideration

In order to ensure a proper operation of AIC2359, the following points should be managed comprehensively.

1. The input capacitor and V_{IN} should be placed as close as possible to each other to reduce the input voltage ripple and noise.
2. The output loop, which is consisted of the inductor, the internal main power switch, the internal synchronous power switch and the output capacitor, should be kept as small as possible.
3. The routes with large current should be kept short and wide.
4. Logically the large current on the converter should flow at the same direction.
5. The VFB pin should be connected to the feedback resistors directly and the route should be away from the noise sources.

■ PHYSICAL DIMENSIONS

● DFN-12 (3x3x0.75-0.45)

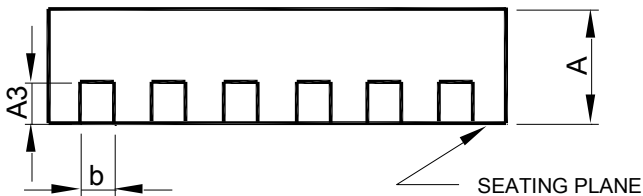
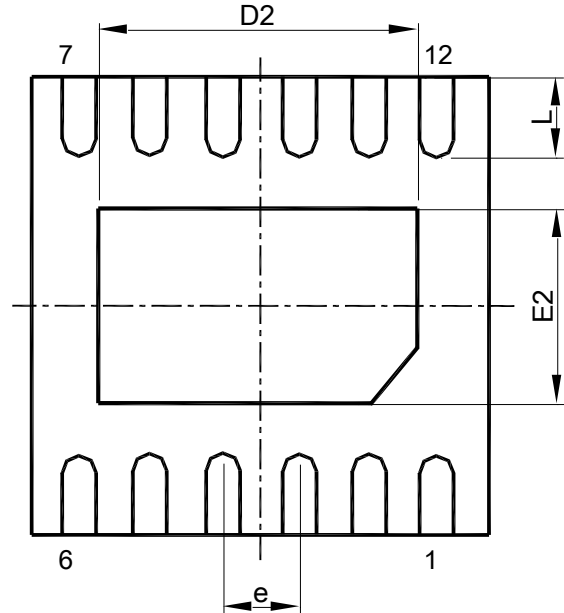
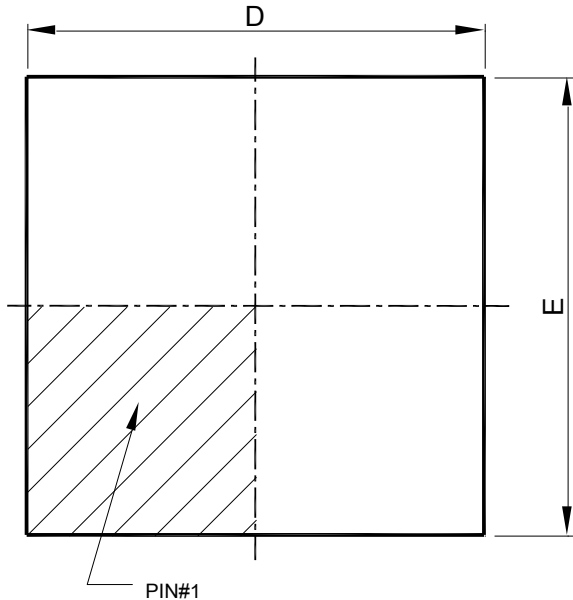

SYMBOL	DFN-12 (3x3x0.75-0.45)	
	MILLIMETERS	
	MIN.	MAX.
A	0.70	0.80
A3	0.20 BSC	
b	0.18	0.30
D	2.90	3.10
D2	2.20	2.70
E	2.90	3.10
E2	1.40	1.80
e	0.45 BSC	
L	0.30	0.50

Note : 1. DIMENSION AND TOLERANCING CONFORM TO ASME Y14.5M-1994.
 2. CONTROLLING DIMENSIONS : MILLIMETER , CONVERTED INCH DIMENSION ARE NOT NECESSARILY EXACT.

Note:

Information provided by AIC is believed to be accurate and reliable. However, we cannot assume responsibility for use of any circuitry other than circuitry entirely embodied in an AIC product; nor for any infringement of patents or other rights of third parties that may result from its use. We reserve the right to change the circuitry and specifications without notice.

Life Support Policy: AIC does not authorize any AIC product for use in life support devices and/or systems. Life support devices or systems are devices or systems which, (i) are intended for surgical implant into the body or (ii) support or sustain life, and whose failure to perform, when properly used in accordance with instructions for use provided in the labeling, can be reasonably expected to result in a significant injury to the user.