

2A, 1.5MHz AOT Synchronous Step-Down DC/DC Converter

FEATURES

- 2.5V to 6V Input Voltage Range
- 2.0A Guaranteed Output Current
- Up to 95% Efficiency
- Low $R_{DS(ON)}$ Internal Switch: 55m Ω
- Stable with Low ESR Output Ceramic Capacitors
- No Schottky Diode Required
- 100% Duty Cycle in Low Dropout Operation
- 1.5MHz Operating Frequency
- Accurate Reference 0.6V Provides Low Output Voltages
- 15 μ A Quiescent Current
- Under Voltage Lockout
- Cycle by Cycle Over Current Protection
- Short Circuit Protection
- Over Temperature Protection
- Available in a DFN-8 (2x1.5x0.75-0.5) and TSOT23-8 Package

DESCRIPTION

The AIC2262 is an adaptive on time control synchronous step down converter. The device features an internal synchronous rectifier for high efficiency; it requires no external Schottky diode.

The AIC2262 main control loop uses adaptive on time control that provides a fast transient response without external compensation component. The low impedance internal MOSFET supports high efficiency operation. The AIC2262 has a proprietary circuit that the device to adapt to all ceramic capacitors.

Other features of the AIC2262 include high efficiency, low dropout voltage, over current protection, short circuit protection, and over temperature protection. It is available in a small DFN-8 (2x1.5x0.75-0.5) and TSOT23-8 package.

APPLICATIONS

- LCD TV
- Multi-function Peripheral
- CPU I/O Supplies
- Cordless Phones
- PDAs and Handy-Terminals
- Battery-Operated Devices (1 Li-Ion or 3 NiMH/ NiCd)

APPLICATIONS CIRCUIT

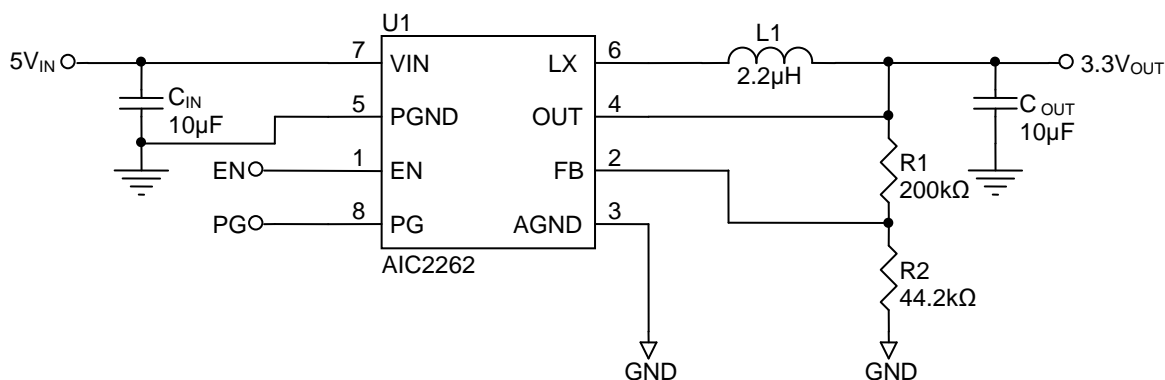

AIC2262 Application Circuit for DFN-8 Package

ORDERING INFORMATION

AIC2262 X XXX XX

PACKING TYPE
 TR: TAPE & REEL
 BG: BAG

 PACKAGE TYPE
 D8A: DFN-8(2x1.5x0.75-0.5)
 K8F: TSOT23-8

 G: Green Package

Example: AIC2262GD8ATR
 → DFN-8 (2x1.5x0.75-0.5) Green
 Package and Tape & Reel
 Package Type

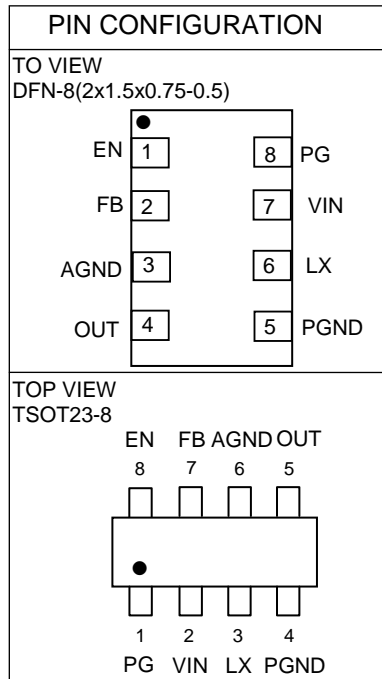

Part No.	Marking
AIC2262GD8A	2262D
AIC2262GK8F	2262G

ABSOLUTE MAXIMUM RATINGS

VIN, LX Voltage	6.5V
EN, FB, OUT & PG Pin Voltage	-0.3 V to VIN
Operating Ambient Temperature Range TA	-40°C to 85°C
Operating Maximum Junction Temperature TJ	150°C
Storage Temperature Range TSTG	-65°C to 150°C
Lead Temperature (Soldering 10 Sec.)	260°C
Thermal Resistance Junction to Case DFN-8 (2x1.5x0.75-0.5)	16°C/W
Thermal Resistance Junction to Ambient DFN-8 (2x1.5x0.75-0.5)	81°C/W
Thermal Resistance Junction to Case TSOT23-8	60°C/W
Thermal Resistance Junction to Ambient TSOT23-8	110°C/W

(Assume no Ambient Airflow)

Absolute Maximum Ratings are those values beyond which the life of a device may be impaired.

ELECTRICAL CHARACTERISTICS

 (T_A=25°C, V_{IN}=5V unless otherwise specified.) (Note 1)

PARAMETER	CONDITIONS	SYMBOL	MIN	TYP	MAX	UNITS
Input Voltage Range		V _{IN}	2.5		6.0	V
Adjustable Output Range		V _{OUT}	V _{REF}		V _{IN} -0.2V	V
Feedback Voltage	V _{IN} = 5V	V _{FB}	0.588	0.6	0.612	V
FB Input Current	V _{FB} = V _{IN}	I _{FB}	-50		50	nA
P-Channel On-Resistance	I _{OUT} = 0.2A	P _{RDS(ON)}		85		mΩ
N-Channel On-Resistance	I _{OUT} = 0.2A	N _{RDS(ON)}		55		mΩ
LX Leakage Current	V _{LX} =0V or V _{LX} =6V		-1		1	μA
Current Limit	V _{IN} = 5V	I _{LMT}	2.6	3.4		A
Quiescent Current	I _{OUT} = 0mA, V _{FB} =V _{REF} + 5%	I _Q		15	25	μA
Shutdown Supply Current	EN = GND	I _{SHDN}		0.1	1	μA
EN High-Level Input Voltage	V _{IN} =2.5V to 5.5V	V _{EN_H}	1.5			V
EN Low-Level Input Voltage	V _{IN} =2.5V to 5.5V	V _{EN_L}			0.4	V
Under Voltage Lockout Threshold	Vin rising	V _{UVLO}	2.0	2.2	2.4	V
Under Voltage Lockout Hysteresis		ΔV _{UVLO}		0.3		V
On-Time	V _{IN} =5V, V _{OUT} =1.2V	T _{ON}		160		ns
	V _{IN} =3.6V, V _{OUT} =1.2V			222		
Operating Frequency	V _{OUT} =1.2V	f _O		1.5		MHz
Minimum Off-Time		T _{OFF(MIN)}		60		ns
Maximum Duty Cycle		D _{MAX}	100			%
Soft-Start Period		T _{SS}		1.5		ms
Power Good Threshold Voltage	Rising referred to V _{FB}			94		%
Power Good Hysteresis				10		%
Power Good Delay				50		μS
Power Good Voltage Low	Sink 1mA	V _{PGL}			0.4	V
Power Good Voltage High	V _{IN} =5V, V _{FB} =0.6V	V _{PGL}	4.9			V
Power Good Internal Pull Up Resistor		R _{PG}		500		kΩ
Thermal Shutdown Temperature				150		°C
Thermal Shutdown Hysteresis				25		°C

Note 1: Specifications are production tested at T_A=25°C. Specifications over the -40°C to 85°C operating temperature range are assured by design, characterization and correlation with Statistical Quality Controls (SQC).

TYPICAL PERFORMANCE CHARACTERISTICS

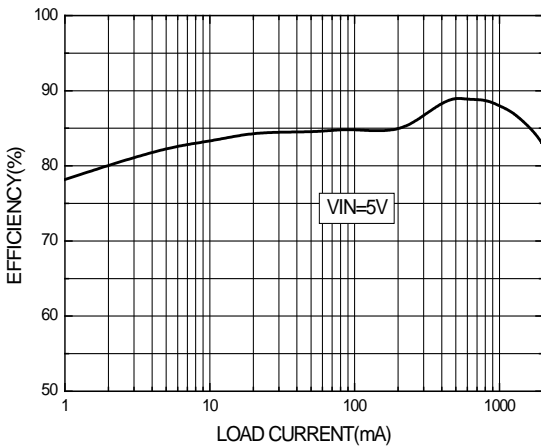

Fig. 1 Efficiency vs. Output Current ($V_{OUT}=1V$)

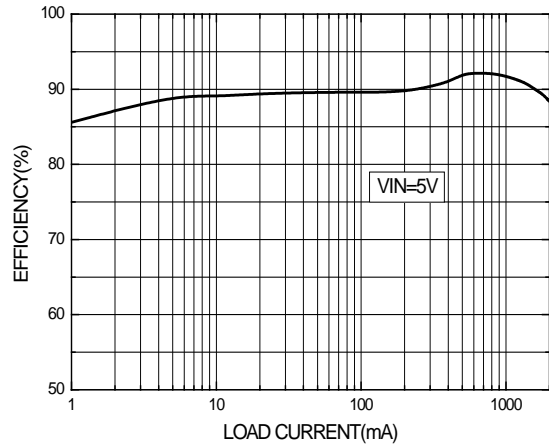

Fig. 2 Efficiency vs. Output Current ($V_{OUT}=1.8V$)

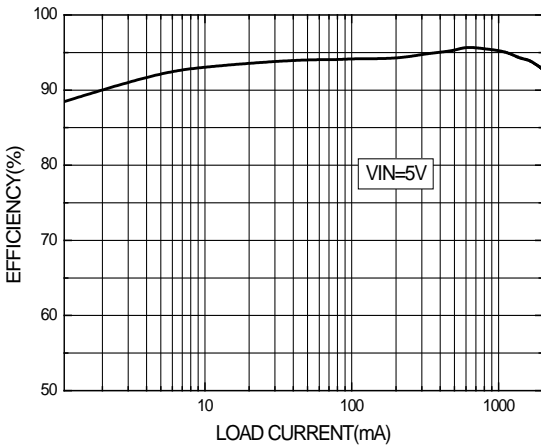

Fig. 3 Efficiency vs. Output Current ($V_{OUT}=3.3V$)

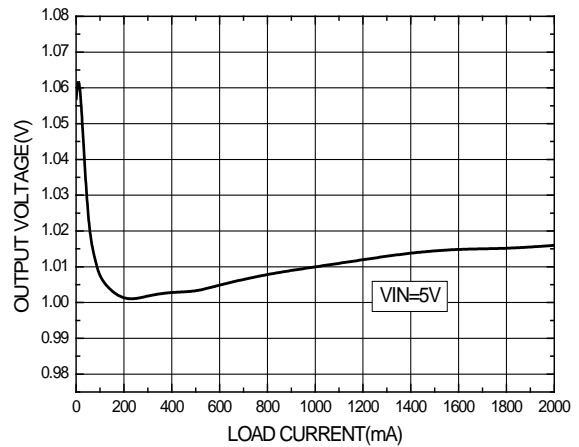

Fig. 4 Output Voltage vs. Load Current ($V_{OUT}=1V$)

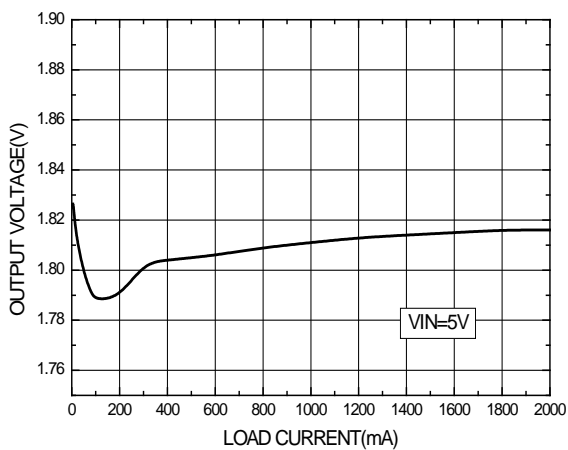

Fig. 5 Output Voltage vs. Load Current ($V_{OUT}=1.8V$)

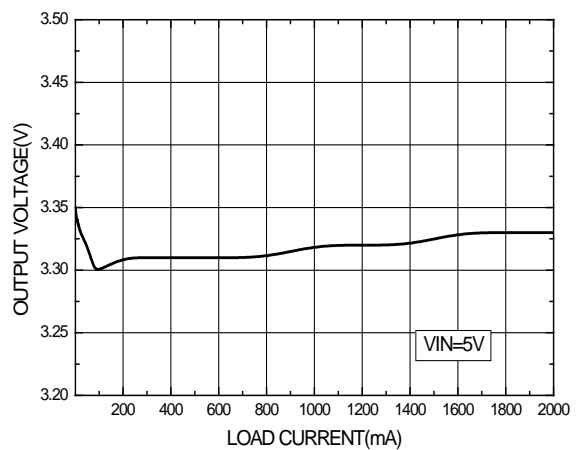

Fig. 6 Output Voltage vs. Load Current ($V_{OUT}=3.3V$)

TYPICAL PERFORMANCE CHARACTERISTICS (Continued)

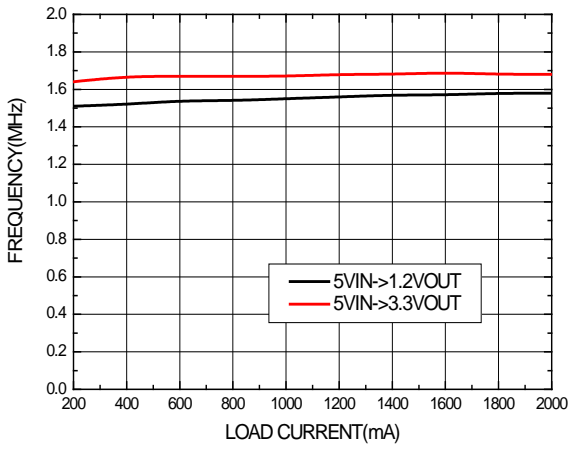

Fig. 7 Frequency vs. Load Current

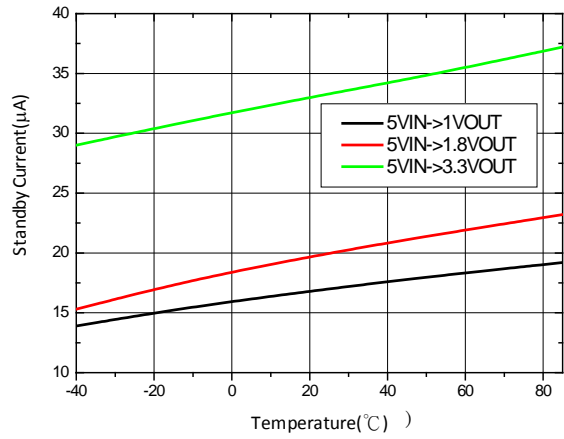

Fig. 8 Standby Current vs. Temperature

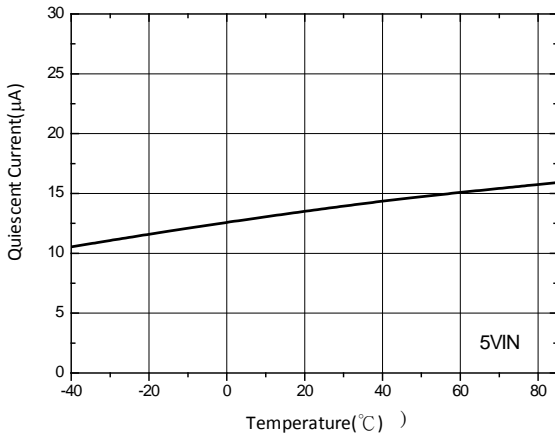

Fig. 9 Quiescent Current vs. Temperature

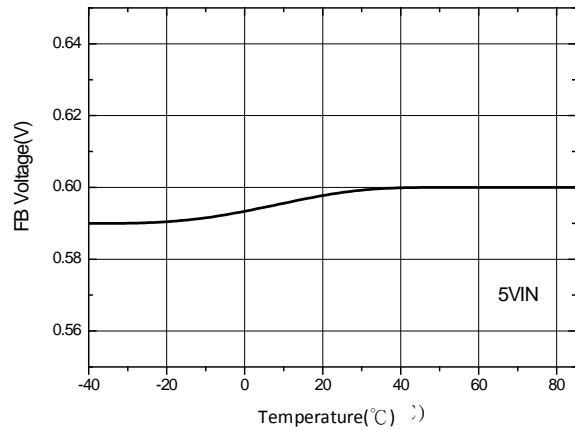

Fig. 10 FB Voltage vs. Temperature

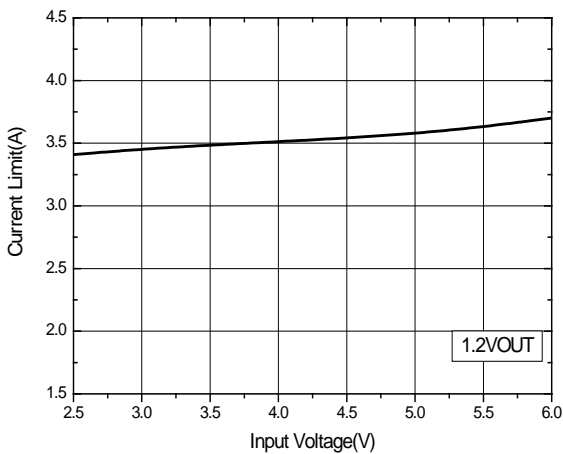

Fig. 11 Current Limit vs. Input Voltage

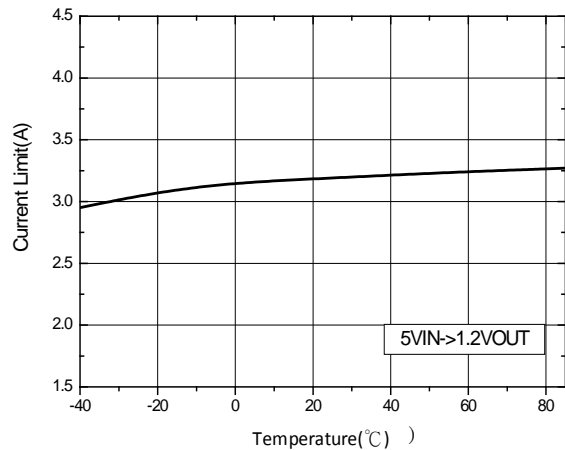

Fig. 12 Current Limit vs. Temperature

■ TYPICAL PERFORMANCE CHARACTERISTICS (Continued)

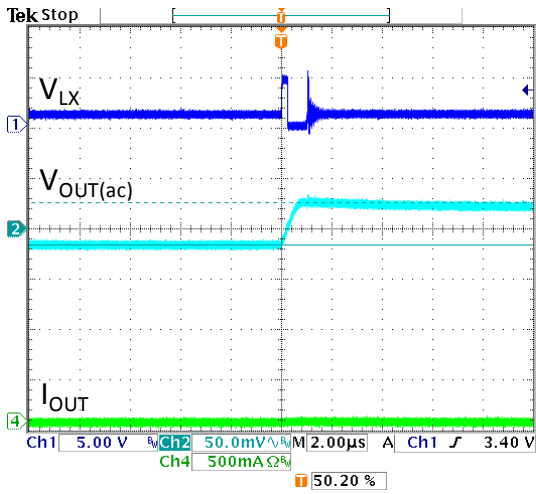

Fig. 13 Output Ripple ($V_{IN}=5V$, $V_{OUT}=1.2V$, $I_{OUT}=0A$)

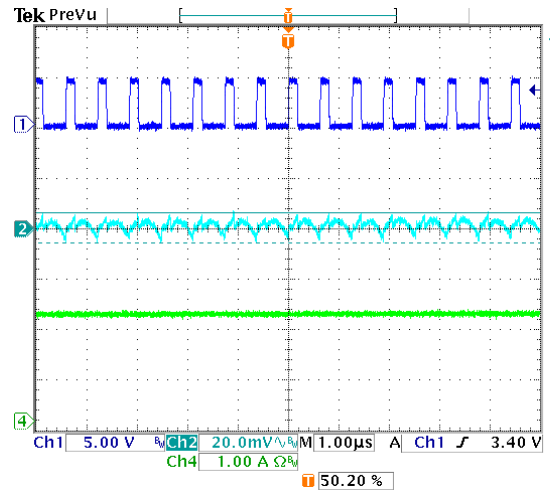

Fig. 14 Output Ripple ($V_{IN}=5V$, $V_{OUT}=1.2V$, $I_{OUT}=2A$)

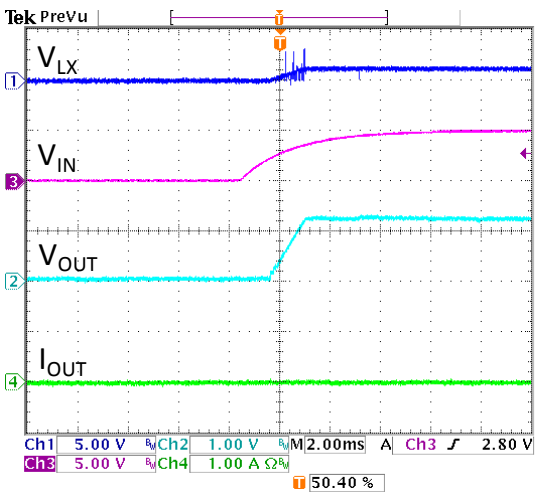

Fig. 15 V_{IN} Power On ($V_{IN}=5V$, $V_{OUT}=1.2V$, $I_{OUT}=0A$)

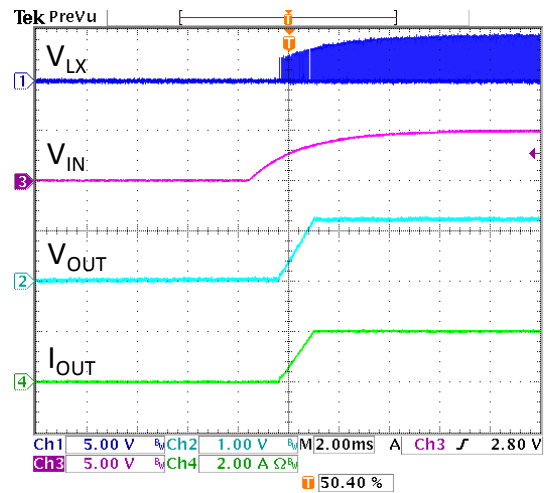

Fig. 16 V_{IN} Power On ($V_{IN}=5V$, $V_{OUT}=1.2V$, $I_{OUT}=2A$)

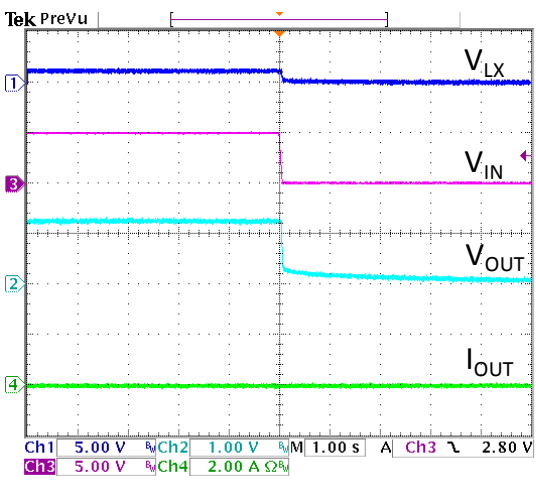

Fig. 17 V_{IN} Power Off ($V_{IN}=5V$, $V_{OUT}=1.2V$, $I_{OUT}=0A$)

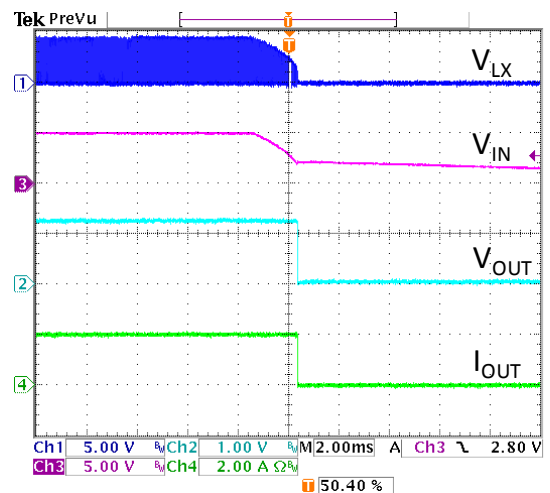

Fig. 18 V_{IN} Power Off ($V_{IN}=5V$, $V_{OUT}=1.2V$, $I_{OUT}=2A$)

■ **TYPICAL PERFORMANCE CHARACTERISTICS (Continued)**

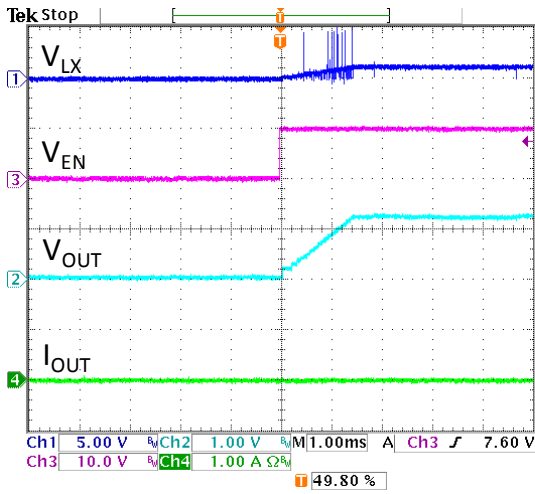

Fig. 19 EN Start Up ($V_{IN}=5V$, $V_{OUT}=1.2V$, $I_{OUT}=0A$)

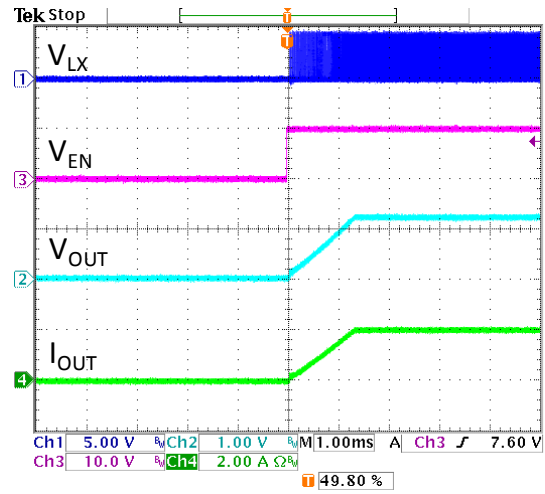

Fig. 20 EN Start Up ($V_{IN}=5V$, $V_{OUT}=1.2V$, $I_{OUT}=2A$)

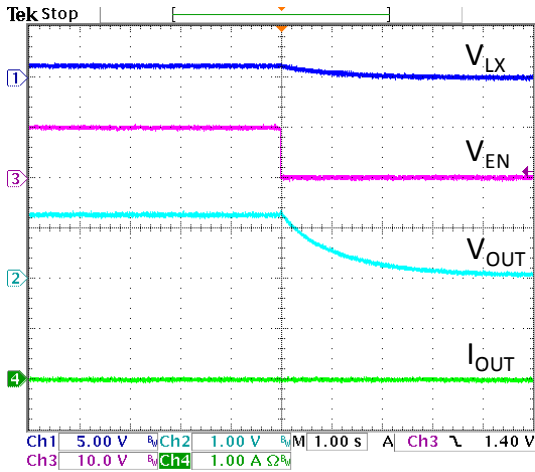

Fig. 21 EN Shutdown ($V_{IN}=5V$, $V_{OUT}=1.2V$, $I_{OUT}=0A$)

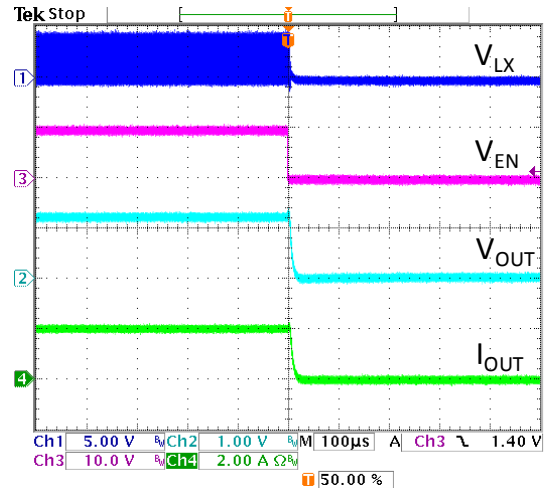

Fig. 22 EN Shutdown ($V_{IN}=5V$, $V_{OUT}=1.2V$, $I_{OUT}=2A$)

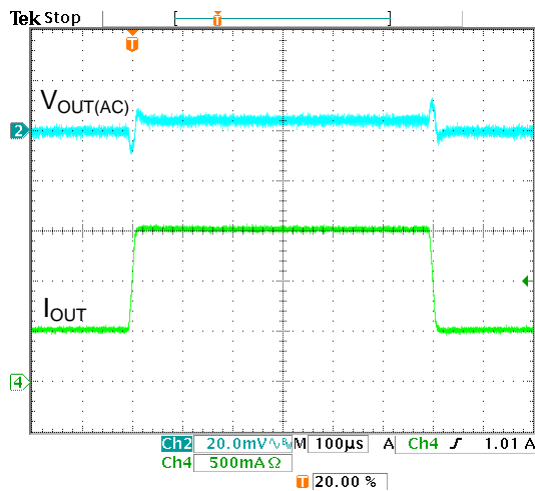
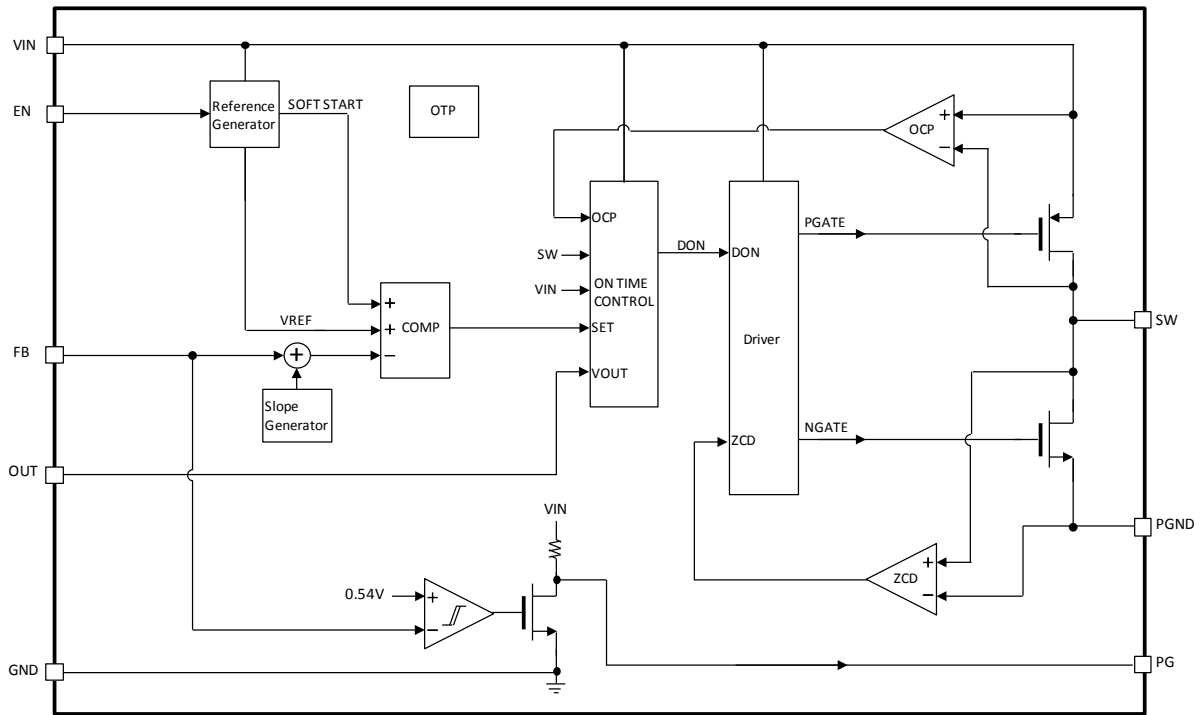

Fig. 23 Load Transient ($V_{IN}=5V$, $V_{OUT}=1.0V$, $I_O=0.5-1.5A$)

■ BLOCK DIAGRAM



Functional Block Diagram of AIC2262

■ PIN DESCRIPTIONS
For DFN-8 (2x1.5x0.75-0.5) PACKAGE

Pin No.	Pin Name	Pin Function
1	EN	Enable Pin. Connect to logic high in normal operation. Forcing this ping to GND causes the device to be shutdown.
2	FB	Feedback Pin. This pin receives the feedback voltage from a resistive divider connecting across the output.
3	AGND	Signal Ground. All small-signal components should connect to this ground, which in turn connects to PGND at one point.
4	OUT	Output Voltage Sense Pin.
5	PGND	Power Ground. Connect this pin to the negative terminal of C _{IN} and C _{OUT} .
6	LX	Internal Power MOSFET Switches Output. Connect this pin to the inductor.
7	VIN	Power Input Supply. Decouple this pin to PGND with a capacitor.
8	PG	Power Good Indicator.

For TSOT23-8 PACKAGE

Pin No.	Pin Name	Pin Function
1	PG	Power Good Indicator.
2	VIN	Power Input Supply. Decouple this pin to PGND with a capacitor.
3	LX	Internal Power MOSFET Switches Output. Connect this pin to the inductor.
4	PGND	Power Ground. Connect this pin to the negative terminal of C _{IN} and C _{OUT} .
5	OUT	Output Voltage Sense Pin.
6	AGND	Signal Ground. All small-signal components should connect to this ground, which in turn connects to PGND at one point.
7	FB	Feedback Pin. This pin receives the feedback voltage from a resistive divider connecting across the output.
8	EN	Enable Pin. Connect to logic high in normal operation. Forcing this ping to GND causes the device to be shutdown.

■ APPLICATION INFORMATION

The AIC2262 is an adaptive on-time control synchronous step down converter that can maintain almost fixed switching frequency over full input voltage range. It can deliver up to 2A output current from 2.5V to 6V input voltage. Unlike the traditional fixed frequency PWM control, the adaptive on-time control has the simpler control circuit and the faster transient response. During normal operation, the AIC2262 can regulate its output voltage through a feedback control circuit, which is composed of a comparator, a ramp generator, a reference generator and several control signal generators. At the beginning of the switching cycle, the main power switch will be turned on and the synchronous power switch will be turned off. The main power switch will be turned off after the internal on-time timer expires. When the main power switch is turned off, the synchronous power switch will be turned on until the summing signal of feedback voltage signal and ramp signal is lower than reference voltage signal or the inductor current starts to reverse. The AIC2262 will enter discontinuous conduction mode (DCM) operation while working at light load conditions.

Enable

When EN is set logic high, AIC2262 is put into active mode operation. By connecting the EN pin to GND, the device can be shutdown to reduce the supply to 0.1 μ A (typical). At this operation mode, the synchronous switch will turn off and the output voltage of step-down converter will reduce to 0V.

Soft Start

AIC2262 provides the soft-start function to prevent a large inrush current and output overshoot during start up period. During the soft-start period, the soft-start

signal will limit the feedback threshold voltage at FB pin. When the soft-start signal voltage is higher than reference voltage, the feedback threshold voltage at FB pin reaches the desired value. The soft-start time is about 1.5ms (typical).

Power Good Indicator

AIC2262 contains an on-chip comparator for power good detection. If the output voltage is lower than power good low threshold, the output voltage of PG pin will be pulled low.

Over Current Protection

The AIC2262 has a cycle-by-cycle current limit to protect the internal power switches. The cycle-by-cycle current limit protection directly limits inductor peak current. When the current limit protection is activated for nine consecutive switching cycles, the AIC2262 will shut down the output power stage and then initiate the soft-start sequence. If the over current condition still exists after the soft-start ends, the AIC2262 will repeat this operation mode until the over current condition is released.

Over Temperature Protection

The AIC2262 includes a thermal-limiting circuit, which is designed to protect the device from excessive temperature. When the junction temperature exceeds $T_J=150^{\circ}\text{C}$, the thermal-limiting circuit turns the internal power switches off and allows the IC to cool. The hysteresis of the over temperature protection is 25 $^{\circ}\text{C}$ (typical).

100% Duty Cycle Operation

When the input voltage approaches the output voltage, the AIC2262 smoothly transits to 100% duty cycle operation. This allows AIC2262 to regulate the

output voltage until AIC2262 completely enters 100% duty cycle operation. In 100% duty cycle mode, the output voltage is equal to the input voltage minus the voltage, which is the drop across the main power switch.

The AIC2262 achieves 100% duty cycle operation by extending the turn-on time of the main power switch. While the input voltage approaches the output voltage, the switching frequency of power switches reduces gradually to smoothly transit to 100% duty cycle operation.

If input voltage is very close to output voltage, the switching mode goes from adaptive on-time control mode to 100% duty cycle operation. During this transient state mentioned above, large output ripple voltage may appear on output terminal.

Components Selection

Inductor

A 2.2μH inductor is recommended for most AIC2262 applications. Although small size and high efficiency are major concerns, the inductor should have low core losses at operation frequency and low ESR. For most designs, the inductance value can be derived from the following equations:

$$L \geq \frac{V_{OUT}}{f_{OSC} \cdot \Delta I_L} \left(1 - \frac{V_{OUT}}{V_{IN}} \right)$$

Where ΔI_L is the inductor ripple current.

In addition, it is important to ensure the inductor saturation current exceeds the peak value of inductor current in application to prevent core saturation. The peak inductor current can be calculated from:

$$I_{PEAK} = I_{OUT(max)} + \frac{V_{OUT}}{2 \times f_{OSC} \cdot L} \left(1 - \frac{V_{OUT}}{V_{IN}} \right)$$

Input Capacitor Selection

To prevent the high input voltage ripple and noise resulted from high frequency switching, the use of low ESR ceramic capacitor for the maximum RMS current is recommended. The approximated RMS current of the input capacitor can be calculated according to the following equation.

$$I_{CINRMS} \approx \sqrt{I_{OUT(MAX)}^2 \times \frac{V_{OUT}(V_{IN} - V_{OUT})}{V_{IN}^2} + \frac{\Delta I_L^2}{12}}$$

Low ESR, X5R or X7R, ceramic capacitors are ideal for this function. The capacitor should be placed as close to the IC as possible for the best. At least a 10μF ceramic capacitor is suggested for the input capacitor.

Output Capacitor Selection

The selection of output capacitor depends on the required output voltage ripple. The output voltage ripple can be expressed as:

$$\Delta V_{OUT} = \frac{\Delta I_L}{8 \times f_{OSC} \cdot C_{OUT}} + ESR \cdot \Delta I_L$$

The output capacitor limits the output ripple during large load transient. For low output voltage ripple, the use of low ESR, X5R or X7R, ceramic capacitor is recommended. When choosing output capacitors, the voltage rating of output capacitor should be higher than the output voltage. 10μF ceramic capacitor may be needed for the output capacitor.

Setting the Output Voltage

An external resistor divider connected from the output voltage to FB is used to set the output voltage. The voltage divider divides the output voltage down to the feedback voltage by the ratio:

$$V_{FB} = V_{OUT} \frac{R_2}{R_1 + R_2}$$

The resistive divider should sit as close to FB pin as possible.

PCB Layout Guidance

In order to ensure a proper operation of AIC2262, the following points should be managed comprehensively.

1. The input capacitor and V_{IN} should be placed as close as possible to each other to reduce the input voltage ripple and noise.
2. The output loop, which is consisted of the inductor, the internal power switch and the output capacitor, should be kept as small as possible.
3. The routes with large current should be kept short and wide.
4. Logically the large current on the converter should flow at the same direction.
5. In order to prevent the effect from noise, the IC's GND pin should be placed close to the ground of the input bypass capacitor.
6. The FB pin should be connected to the feedback resistors directly and the route should be away from the noise sources.

APPLICATION EXAMPLES

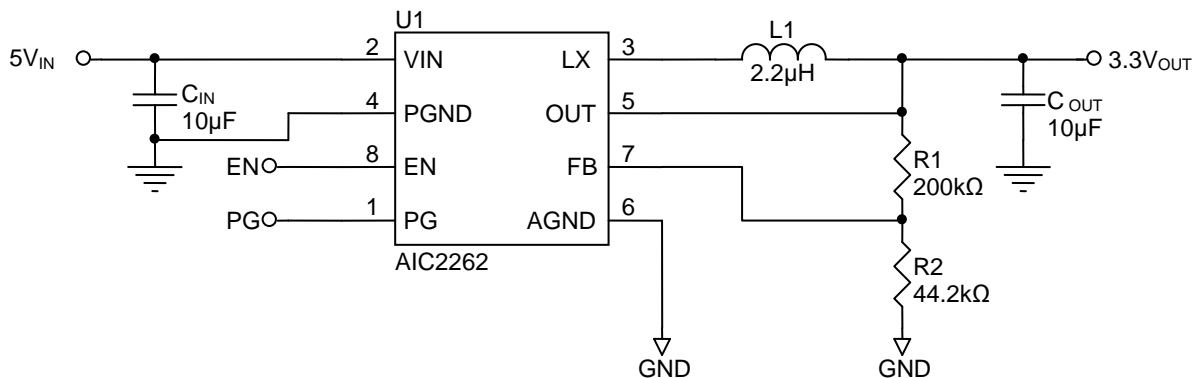
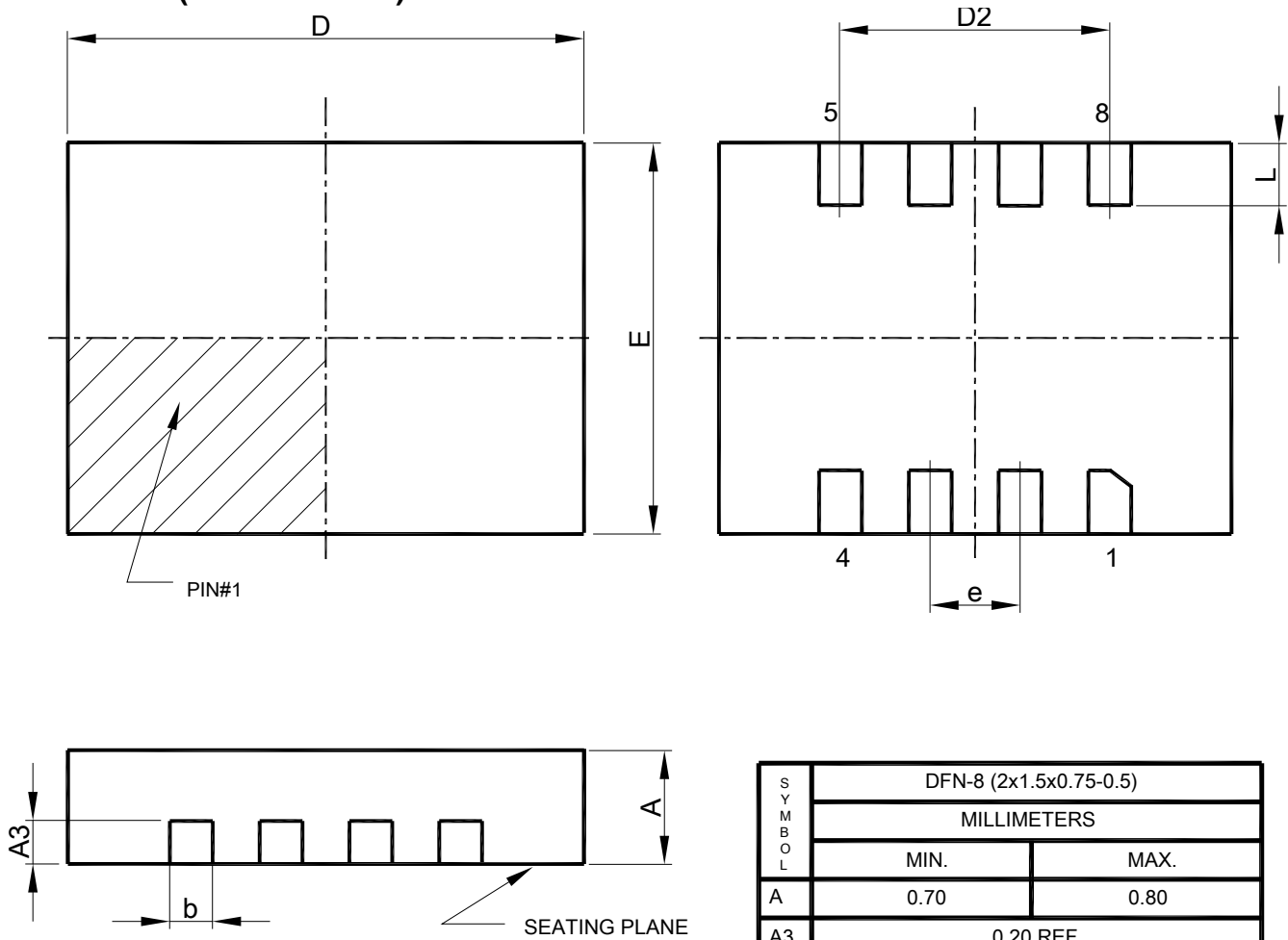

Fig. 24 AIC2262 Application Circuit for TSOT23-8 Package

PHYSICAL DIMENSIONS

- DFN-8 (2x1.5x0.75-0.5)



SYMBOL	DFN-8 (2x1.5x0.75-0.5)	
	MILLIMETERS	
	MIN.	MAX.
A	0.70	0.80
A3	0.20 REF	
b	0.20	0.30
D	1.90	2.10
E	1.40	1.60
e	0.50 BSC	
L	0.30	0.40

Note : 1.CONTROLLING DIMENSIONS : MILLIMETER , CONVERTED INCH DIMENSION ARE NOT NECESSARILY EXACT.

• TSOT23-8

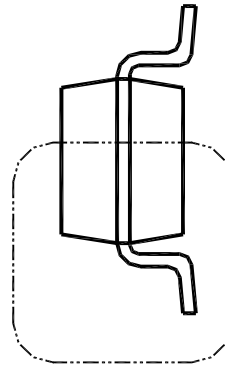
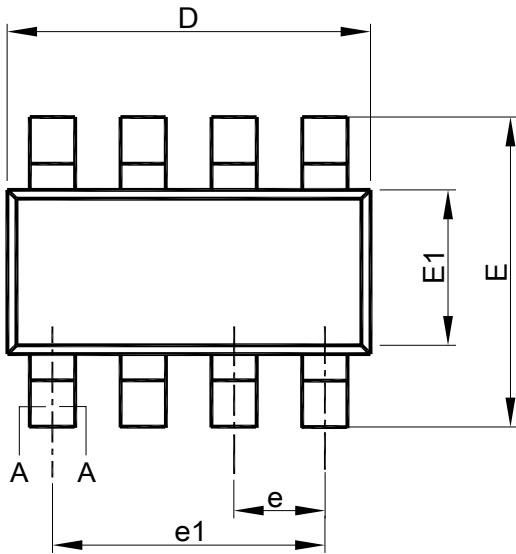

SEE VIEW B

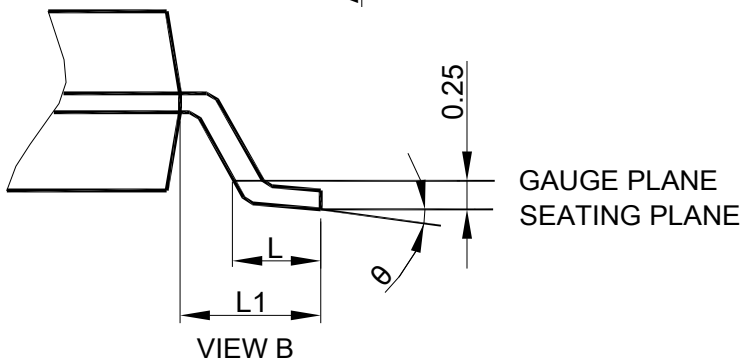
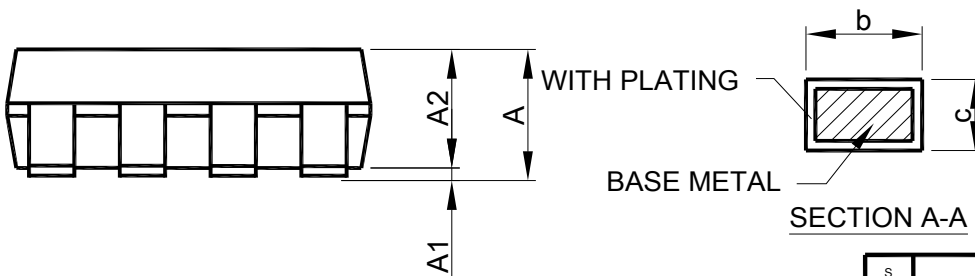

VIEW B

SYMBOL	TSOT23-8	
	MILLIMETERS	
	MIN.	MAX.
A	-	1.00
A1	0	0.10
A2	0.70	0.90
b	0.20	0.40
c	0.08	0.22
D	2.80	3.00
E	2.60	3.00
E1	1.50	1.70
e	0.65 BSC	
e1	1.95 BSC	
L	0.30	0.60
L1	0.60 REF	
θ	0°	8°

- Note :
1. Refer to JEDEC MO-193E.
 2. Dimension "D" does not include mold flash, protrusions or gate burrs. Mold flash, protrusion or gate burrs shall not exceed 6 mil per side.
 3. Dimension "E1" does not include inter-lead flash or protrusions.
 4. Controlling dimension is millimeter, converted inch dimensions are not necessarily exact.

Note:

Information provided by AIC is believed to be accurate and reliable. However, we cannot assume responsibility for use of any circuitry other than circuitry entirely embodied in an AIC product; nor for any infringement of patents or other rights of third parties that may result from its use. We reserve the right to change the circuitry and specifications without notice.

Life Support Policy: AIC does not authorize any AIC product for use in life support devices and/or systems. Life support devices or systems are devices or systems which, (i) are intended for surgical implant into the body or (ii) support or sustain life, and whose failure to perform, when properly used in accordance with instructions for use provided in the labeling, can be reasonably expected to result in a significant injury to the user.