

PFM Mode Step-Up DC/DC Converter With True Shutdown

FEATURES

- Adjustable Output Voltage up to 24V.
- 2.7V to 5.5V Input Range.
- Maximum 0.1 μ A Shutdown Current.
- Tiny Inductor and Capacitors are allowed.
- Space-Saving SOT-23-6 Package.

APPLICATIONS

- LCD Bias
- LCM
- OLED Driver

DESCRIPTION

AIC3632 is a pulse-frequency modulation (PFM), step-up DC/DC Converter. The built-in high voltage N-channel MOSFET allows AIC3632 for step-up applications with up to 24V output voltage, as well as for Single Ended Primary Inductance Converter (SEPIC) and other low-side switching DC/DC converter.

The AIC3632 is available in a space-saving SOT-23-6 package.

TYPICAL APPLICATION CIRCUIT

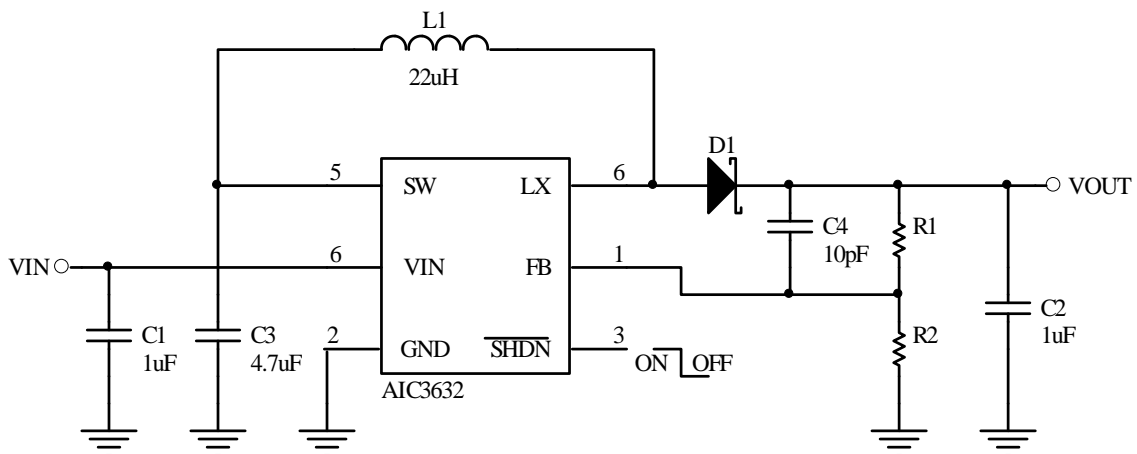

Typical Application Circuit

ORDERING INFORMATION

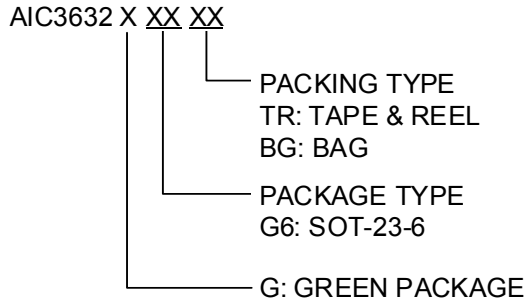

Example: AIC3632GG6TR
 → in SOT-23-6 Green Package and Tape & Reel Packing Type

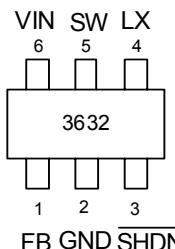
ORDER NUMBER	PIN CONFIGURATION
AIC3632GG6 (SOT-23-6)	FRONT VIEW  <p>Note: Pin1 is determined by orienting the package marking as shown.</p>

SOT-23-6 Marking

Part No.	Marking
AIC3632GG6	3632G

ABSOLUTE MAXIMUM RATINGS

LX to GND	28V
FB to GND	6V
VIN, SW, <u>SHDN</u>	6V
SW Pin RMS Current	0.6A
Operating Ambient Temperature Range T_A	-40°C to 85°C
Operating Maximum Junction Temperature T_J	125°C
Storage Temperature Range T_{STG}	-65°C to 150°C
Lead Temperature (Soldering 10 Sec.)	260°C
Thermal Resistance Junction to Case SOT-23-6	115°C/W
Thermal Resistance Junction to Ambient SOT-23-6	250°C/W

(Assume no Ambient Airflow, no Heatsink)

Absolute Maximum Ratings are those values beyond which the life of a device may be impaired.

TEST CIRCUIT

Refer to "TYPICAL APPLICATION CIRCUIT".

■ ELECTRICAL CHARACTERISTICS

($V_{IN}=V_{SHDN}=3.6V$, SW=Open, $T_A=25^{\circ}C$, unless otherwise specified) (Note 1)

PARAMETER	SYMBOL	CONDITIONS	MIN	TYP	MAX	UNITS
Input Supply Range	V_{IN}		2.7		5.5	V
Output Voltage Adjust Range	V_{OUT}				24	V
V_{IN} Undervoltage Lockout	UVLO	V_{IN} rising, 50mV hysteresis	2.33	2.5	2.65	V
Quiescent Current	I_{IN}	$V_{FB} = 1.3V$, No switching		30	50	μA
Shutdown Supply Current		$V_{SHDN} = 0V$		0.01	0.5	μA
ERROR AMPLIFIER						
Feedback Voltage	V_{FB}	At $0^{\circ}C$ to $85^{\circ}C$, Note 1	1.2076	1.226	1.2444	V
FB Input Bias Current	I_{FB}	$V_{FB} = 1.24V$	-50		50	nA
Line Regulation		$V_{IN} = 2.7V$ to $5.5V$		0.1		%/V
Load Regulation		$V_{OUT} = 15V$, $I_{LOAD} = 0$ to $5mA$		0.1		%/mA
OSCILLATOR						
Minimum LX Off-Time		$V_{FB} > 1.1V$		1		μS
		$V_{FB} = 0.1V$		5		
POWER SWITCH						
On-Resistance	$R_{DS(ON)}$	$V_{IN} = 5V$		0.6	1	Ω
Leakage Current	$I_{LX(OFF)}$	$V_{LX} = 28V$		0.1	2	μA
Switch Current Limit	I_{LX}		0.078	0.101	0.118	A
SOFT-START						
SW PMOS ON-Resistance		$V_{IN} = 2.7V$, $I_{SW} = 100mA$		1.5	2.5	Ω
SW PMOS Current Limit		$V_{IN} = 3.6V$, $V_{SW} = 0V$	0.4	0.85	1.1	A
SW PMOS Leakage Current		$V_{IN} = 5.5V$, $V_{SW} = 0V$			1	μA
SW PMOS Soft Start Time		$V_{IN} = 2.7V$, $C_{SW} = 4.7\mu F$		0.2	1	mS
CONTROL INPUT						
SHDN Input Low Voltage	V_{IL}				0.7	V
SHDN Input High Voltage	V_{IH}		1.5			V
SHDN Input Current	I_{SHDN}	$V_{SHDN} = 0V$		0.01	0.1	μA

Note 1: Specifications are production tested at $T_A=25^{\circ}C$. Specifications over the $-40^{\circ}C$ to $85^{\circ}C$ operating temperature range are assured by design, characterization and correlation with Statistical Quality Controls (SQC).

TYPICAL PERFORMANCE CHARACTERISTICS

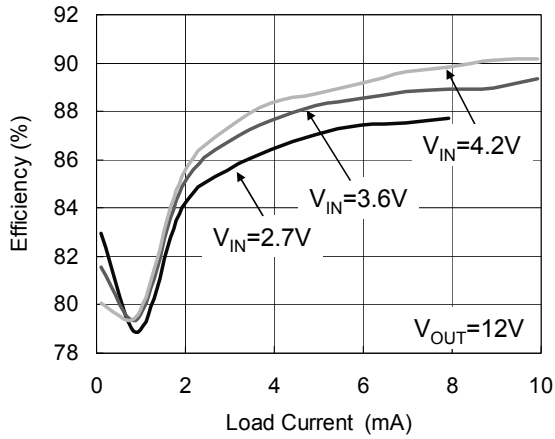

Fig. 1 Efficiency vs. Load Current

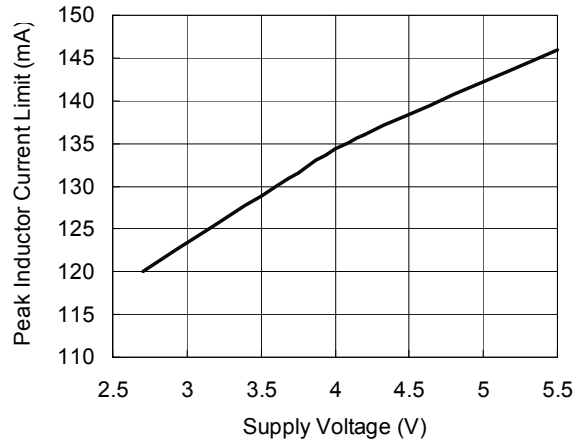

Fig. 2 Peak Inductor Current Limit vs. Supply Voltage

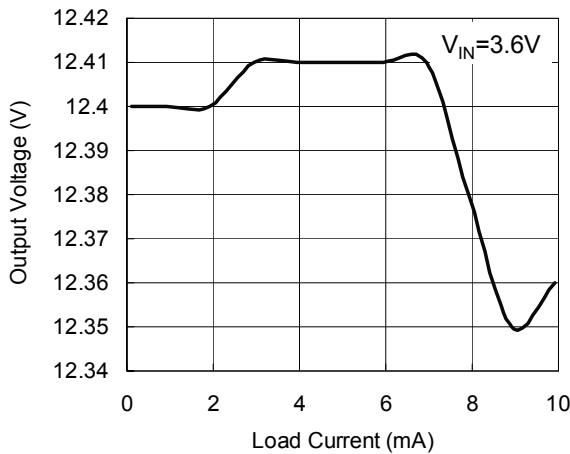

Fig. 3 Output Voltage vs. Load Current

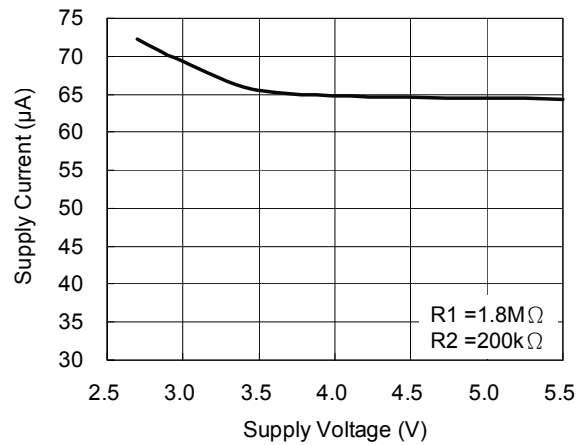

Fig. 4 Supply Current vs. Supply Voltage

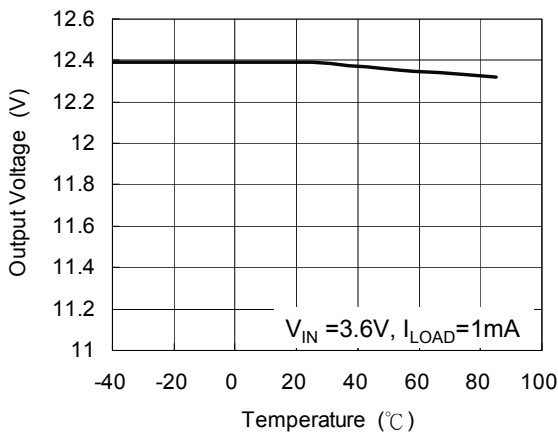

Fig. 5 Output Voltage vs. Temperature

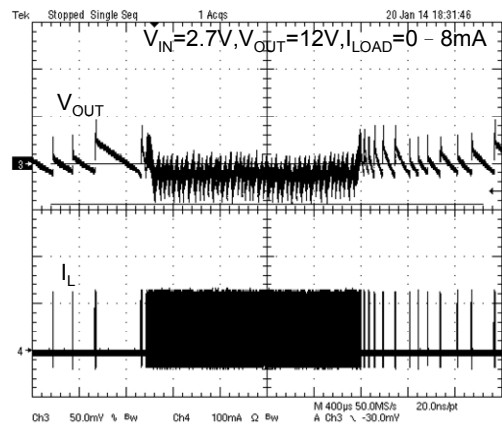

Fig. 6 Load Transient Response

TYPICAL PERFORMANCE CHARACTERISTICS(Continued)

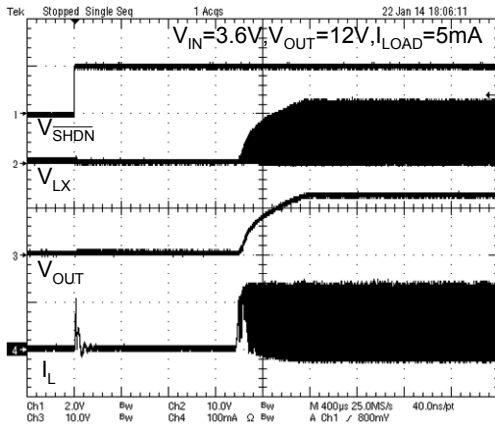

Fig. 7 Start Up Waveform

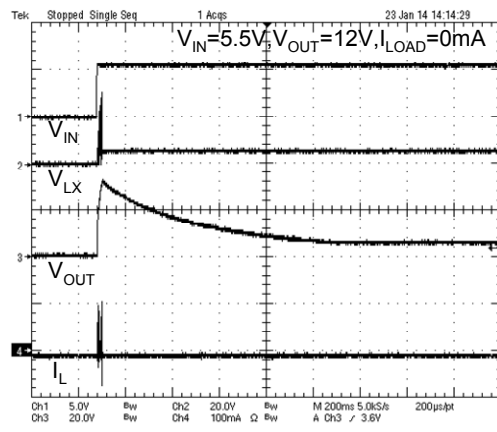

Fig. 8 Over Voltage Protection

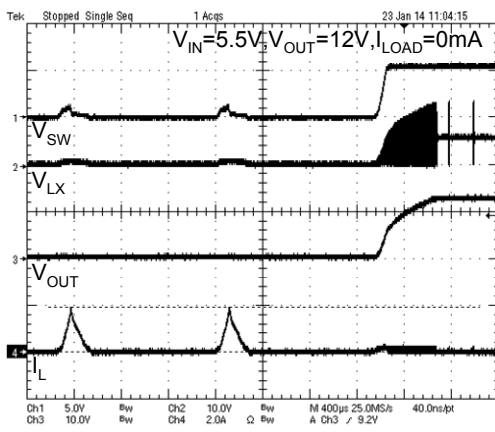
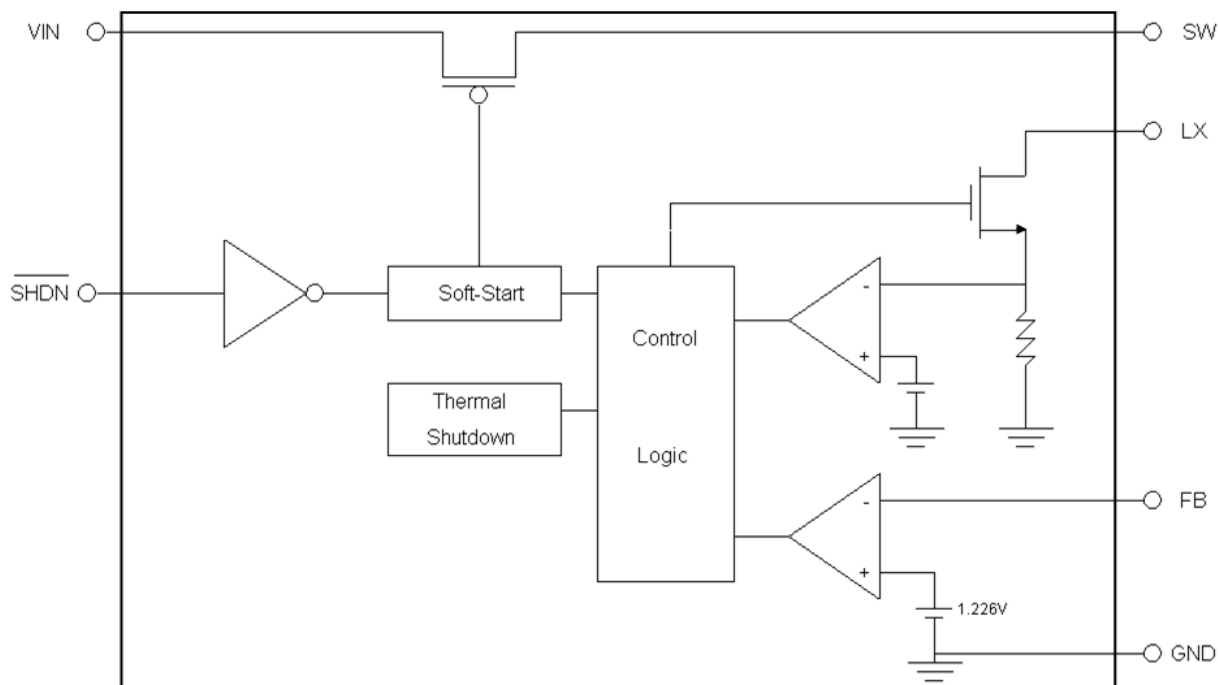

Fig. 9 Short Circuit Release

■ BLOCK DIAGRAM



■ PIN DESCRIPTIONS

PIN 1: FB - Feedback Input. Connect a resistive voltage divider from the output to FB to set the output voltage.

PIN 2: GND - Ground.

PIN 3: $\overline{\text{SHDN}}$ - Shutdown Input. Drive $\overline{\text{SHDN}}$ low to turn off the converter. To automatically start the converter, connect $\overline{\text{SHDN}}$ to IN. Do not leave $\overline{\text{SHDN}}$ unconnected.

PIN 4: LX - Inductor Switching Connection.

PIN 5: SW - Power Switching Connection. Connect SW to inductor and output rectifier. Keep the distance between the components as close to SW as possible.

PIN 6: VIN - Internal Bias Voltage Input. Connect VIN pin to the input voltage source. Bypass VIN to GND with a capacitor sitting as close to VIN pin as possible.

■ APPLICATION INFORMATION

The AIC3632 is a step-up DC-DC converter. It is based on PFM control topology. At the beginning of each switching cycle, the main switch (NMOS) is turned on and the inductor current starts to ramp. When the sensing current signal equals the main switch current limit value, the main switch is turned off and the inductor current flows through diode to supply the output. The AIC3632 has true-shutdown feature which has an internal P-channel MOSFET connecting from VIN pin to SW pin to protect main switch, diode and inductor during operation period. The AIC3632 can operate with an input voltage from 2.7V to 5.5V and adjustable output voltage up to 24V.

Device Shutdown

When $\overline{\text{SHDN}}$ pin is set logic high, the AIC3632 is put into active mode operation. If $\overline{\text{SHDN}}$ pin is set logic low, the device is put into shutdown mode and consumes less than 0.5 μ A of current. At the shutdown mode, the internal P-channel MOSFET will turn off and the output voltage of AIC3632 step-up converter will reduce to 0V.

Under-Voltage Lockout

Under-Voltage Lockout (UVLO) prevents the main switch from turning on until input voltage exceeds 2.5V typically. When the main switch turns on, if the input voltage drops below 2.4V typically, UVLO shuts off the main switch.

Adjustable Output Voltage

An external resistor divider is used to set the output voltage. The output voltage of the switching regulator (V_{OUT}) is determined by the following equation:

$$V_{\text{OUT}} = V_{\text{FB}} \times \left(1 + \frac{R_1}{R_2} \right)$$

Where V_{FB} is 1.226V reference voltage.

Short Circuit Protection

While the output is shorted to ground, the surge current will flow through the internal P-channel MOSFET. If the surge current reaches the PMOS current limit, the internal P-channel MOSFET will turn off and restart soft-start. This would protect the inductor and diode from damage and make sure downstream circuits are safe.

Soft-Start

The AIC3632 has soft-start function it can prevent large inrush current during start-up period. During soft-start period, the internal P-channel switch will turn on slowly.

Over Voltage Protection

If the feedback resistor is floating or other situation is happened to make the output voltage over normal voltage, the AIC3632 will stops switching, and the output voltage will reduce to VIN voltage.

Inductor Selection

A 22 μ H inductor is recommended for most AIC3632 applications. It is important to ensure the inductor saturation current value exceeds the peak value of inductor current in application to prevent core saturation.

Diode Selection

Schottky diodes, with their low forward voltage drop and fast reverse recovery, are the ideal choices for AIC3632 applications. The forward voltage drop of an Schottky diode represents the conduction losses in the diode, while the diode capacitance (CT or CD) represents the switching losses. For diode selection, both forward voltage drop and diode capacitance need to be considered. In addition, the rating of selected Schottky diode should be able to handle the output voltage and the maximum peak diode current.

Capacitor Selection

The small size of ceramic capacitors makes them ideal for AIC3632 applications. When choosing the input and output ceramic capacitors, low ESR/ESL X5R and X7R types are recommended because they retain their capacitance over wider ranges of voltage and temperature than other types. A $1\mu\text{F}$ input capacitor and a $1\mu\text{F}$ output capacitor are sufficient for most applications. The SW pin is suggested to connect a $4.7\mu\text{F}$ or greater bypass capacitor. A 10pF feed-forward capacitor connected between output and FB pin is recommended, it can improve stability for most applications.

PCB Layout Guidance

This is a considerably high frequency for DC-DC converters. PCB layout is important to guarantee satisfactory performance. It is recommended to make traces of the power loop, especially where the switching node is involved, as short and wide as possible. First of all, the inductor, input and output capacitor should be as close to the device as possible. Feedback and shutdown circuits should avoid the proximity of large AC signals involving the power inductor and switching node.

APPLICATION EXAMPLE

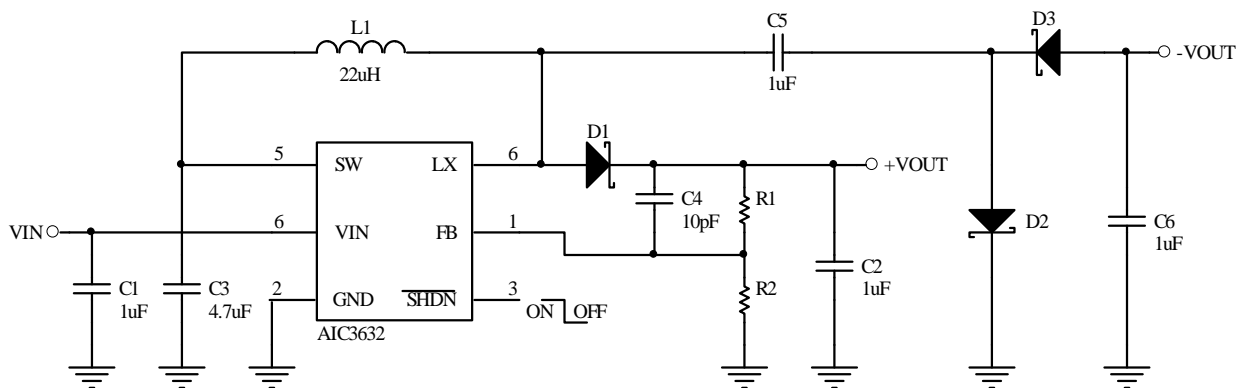
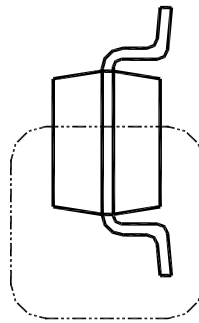
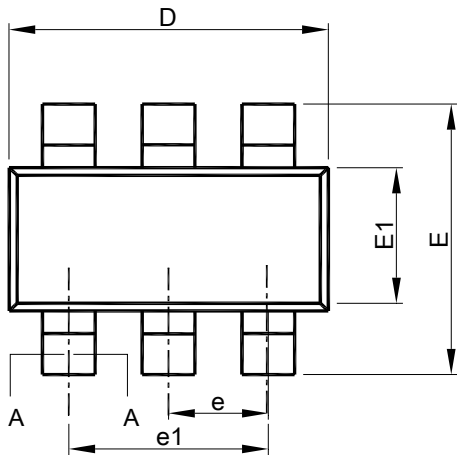
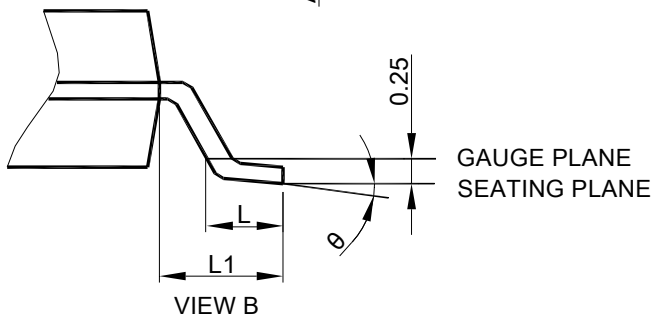
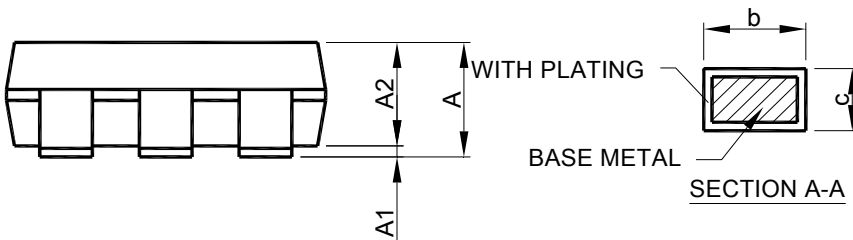

Fig. 10 Dual Output Application

PHYSICAL DIMENSIONS (unit: mm)
SOT-23-6

SEE VIEW B



VIEW B

SYMBOL	SOT-23-6	
	MILLIMETERS	
	MIN.	MAX.
A	0.95	1.45
A1	0.00	0.15
A2	0.90	1.30
b	0.30	0.50
c	0.08	0.22
D	2.80	3.00
E	2.60	3.00
E1	1.50	1.70
e	0.95 BSC	
e1	1.90 BSC	
L	0.30	0.60
L1	0.60 REF	
θ	0°	8°

- Note :
1. Refer to JEDEC MO-178AB.
 2. Dimension "D" does not include mold flash, protrusions or gate burrs. Mold flash, protrusion or gate burrs shall not exceed 10 mil per side.
 3. Dimension "E1" does not include inter-lead flash or protrusions.
 4. Controlling dimension is millimeter, converted inch dimensions are not necessarily exact.

Note:

Information provided by AIC is believed to be accurate and reliable. However, we cannot assume responsibility for use of any circuitry other than circuitry entirely embodied in an AIC product; nor for any infringement of patents or other rights of third parties that may result from its use. We reserve the right to change the circuitry and specifications without notice.

Life Support Policy: AIC does not authorize any AIC product for use in life support devices and/or systems. Life support devices or systems are devices or systems which, (i) are intended for surgical implant into the body or (ii) support or sustain life, and whose failure to perform, when properly used in accordance with instructions for use provided in the labeling, can be reasonably expected to result in a significant injury to the user.