

# 5A 16V 700kHz Synchronous Step-Down Converter

## FEATURES

- 5A Output Current
- Wide 4.5V to 16V Operating Input Range
- Output Adjustable from 0.8V to 6V
- Up to 91% efficiency
- Low Rds(on) Internal Switch
- Constant On Time Control
- Fast Transient Response
- Pseudo 700kHz Switching Frequency
- Programmable Soft Start
- Thermal Shutdown
- Cycle by Cycle Over Current Protection
- Short Circuit Protection
- Thermal Shutdown
- Available in SOP-8 Exposed Pad Package

## APPLICATIONS

- Digital TV Power Supply
- High Definition Blu-ray Players
- Networking Home Terminal
- Set Top Box

## DESCRIPTION

The AIC2865 is a constant on time control synchronous step down converter. The AIC2865 enables system designers to complete various power bus regulators with a cost effective, low component count, low standby current.

The AIC2865 main control loop uses constant on time control that provides a fast transient response without external compensation component. The low impedance internal MOSFETs support high efficiency operation with wide input voltage range form 4.5V to 16V.

The AIC2865 has a proprietary circuit that the device adapts to all ceramic capacitors. The output voltage can be adjustable between 0.8V to 6V. The device also features a programmable soft start time.

This device is available in SOP-8 Exposed Pad package and provides a very compact system solution with minimal external components and PCB area.

## APPLICATIONS CIRCUIT

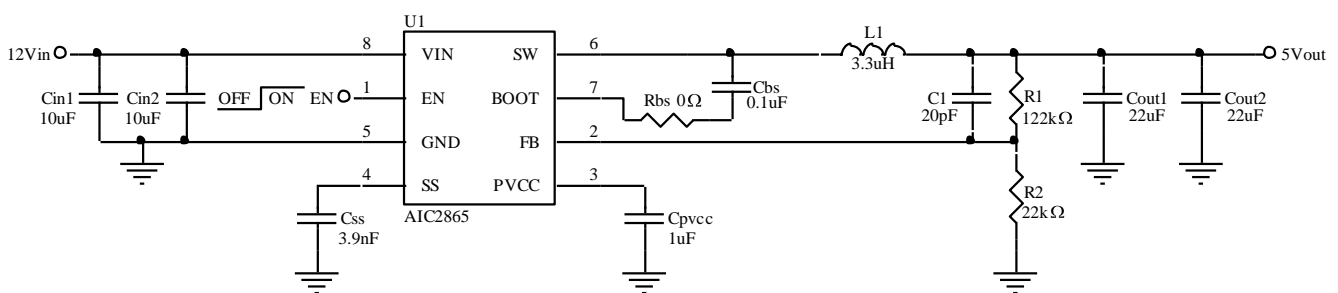

Typical Application Circuit for V<sub>IN</sub>=12V Condition

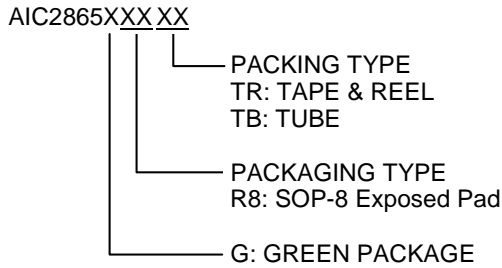
**ORDERING INFORMATION**

Example:

AIC2865GR8TR  
 → Green SOP-8 Exposed Pad Package and  
 TAPE & REEL Packing Type

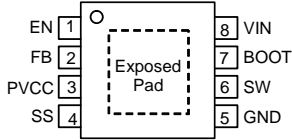
PACKAGE TYPE	PIN CONFIGURATION
R8 (SOP-8 Exposed Pad)	SOP-8 Exposed Pad TOP VIEW  Note: The exposed pad should be connected with GND pin

**ABSOLUTE MAXIMUM RATINGS**

Supply Voltage, $V_{IN}$ .....	-0.3V to 17V
Switch Voltage, SW .....	-0.3V to $V_{IN}+0.3V$
BOOT to SW .....	-0.3V to 6V
All Other Pins .....	-0.3V to 6V
Junction Temperature .....	150°C
Lead Temperature .....	260°C
Storage Temperature Range .....	-65°C to 150°C
Operating Ambient Temperature Range .....	-40°C to 85°C
Thermal Resistance Junction to Case      SOP-8 Exposed Pad* .....	15°C/W
Thermal Resistance Junction to Ambient    SOP-8 Exposed Pad* .....	60°C/W

(Assume no Ambient Airflow)

**Absolute Maximum Ratings are those values beyond which the life of a device may be impaired.**

\*The package is placed on a two layers PCB with 2 ounces copper and 2 square inch, connected by 8 vias.

**ELECTRICAL CHARACTERISTICS**

( $V_{IN}=12V$ ,  $V_{EN}=5V$ ,  $T_A=25^{\circ}C$ , unless otherwise specified.) (Note1)

PARAMETER	SYMBOL	CONDITIONS	MIN	TYP	MAX	UNITS
Operating Voltage	$V_{IN}$		4.5		16	V
<b>Supply Current</b>						
Shutdown Current	$I_{SHDN}$	$V_{EN}=0V$		0.1	1	$\mu A$
Quiescent Current	$I_Q$	$V_{EN}=3V, V_{FB}=1V$		0.7		mA
<b>Logic Threshold</b>						
EN High Level Input Voltage			2.5			V
EN Low Level Input Voltage					0.6	V
<b><math>V_{REF}</math> Voltage and Feedback Input Current</b>						
Feedback Reference Voltage	$V_{REF}$	$V_{IN}=12V$	0.753	0.765	0.777	V
Feedback Input Current	$I_{FB}$	$V_{FB}=0.8V$	-0.15	0	0.15	$\mu A$
<b><math>V_{PVCC}</math> Output</b>						
$V_{PVCC}$ Output Voltage	$V_{PVCC}$	$6V \leq V_{IN} \leq 16V, 0 \leq I_{PVCC} \leq 5mA$	5.0	5.25	5.5	V
Line Regulation		$6V \leq V_{IN} \leq 16V, I_{PVCC}=5mA$			25	mV
Load Regulation		$0 \leq I_{PVCC} \leq 5mA$			100	mV
Output Current	$I_{PVCC}$	$V_{IN}=6V, V_{PVCC}=4V$		110		mA
<b>Switch On Resistance</b>						
High Side Switch On Resistance	$R_{DS(ON)H}$			52		m $\Omega$
Low Side Switch On Resistance	$R_{DS(ON)L}$			42		m $\Omega$
<b>Current Limit</b>						
Current Limit	$I_{LIMIT}$		6.5	7.5		A
<b>Thermal Shutdown</b>						
Thermal Threshold	$T_{SD}$			160		$^{\circ}C$
Thermal Shutdown Hysteresis	$\Delta T_{SD}$			40		$^{\circ}C$
<b>On-Time Timer Control</b>						
On-Time	$t_{ON}$	$V_{IN}=12V, V_{OUT}=1.05V$		150		ns
Minimum Off-Time	$t_{OFF(MIN)}$			260		ns
<b>Soft Start</b>						
SS Charge Current		$V_{SS}=0V$		6		$\mu A$
SS Discharge Current		$V_{SS}=0.5V$		1		mA
<b>Under Voltage Lockout Voltage</b>						
UVLO Threshold		$V_{IN}$ Rising to Wake up $V_{PVCC}$	3.7	4.0	4.3	V
UVLO Hysteresis				300		mV

Note 1: Specifications are production tested at  $T_A=25^{\circ}C$ . Specifications over the  $-40^{\circ}C$  to  $85^{\circ}C$  operating temperature range are assured by design, characterization and correlation with Statistical Quality Controls (SQC).

■ TYPICAL PERFORMANCE CHARACTERISTICS

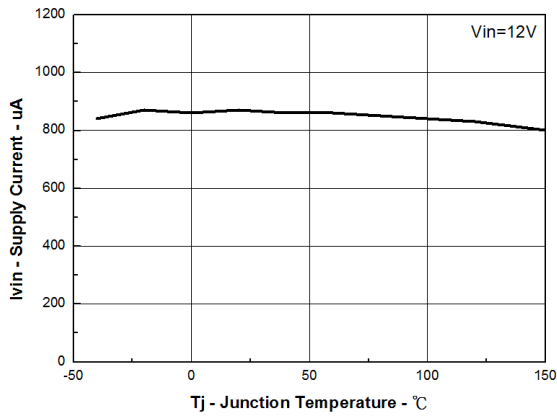

Fig. 1 Supply Current vs. Junction Temperature

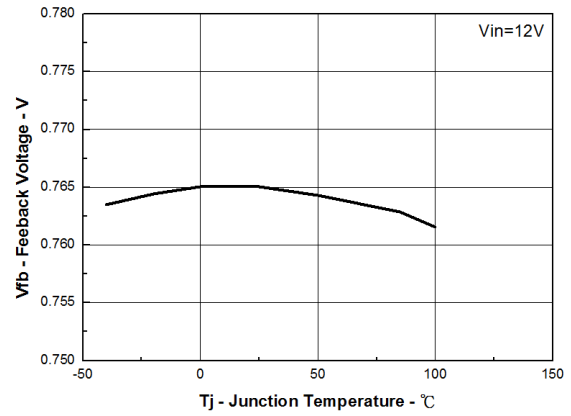

Fig. 2 Feedback Voltage vs. Junction Temperature

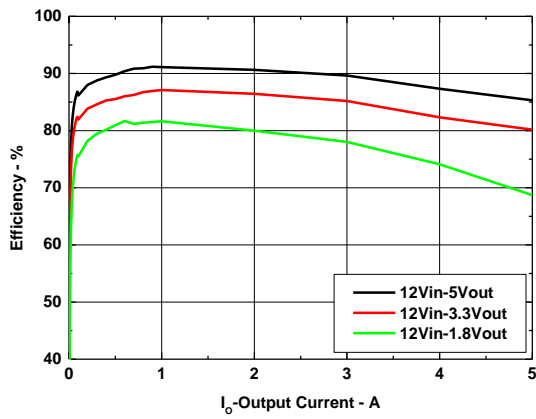

Fig. 3 Efficiency vs. Output Current

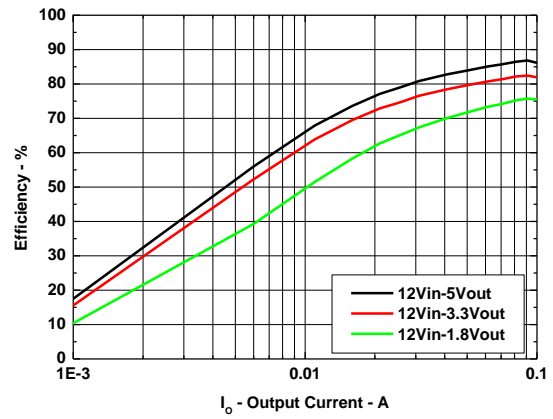

Fig. 4 Light Load Efficiency vs. Output Current

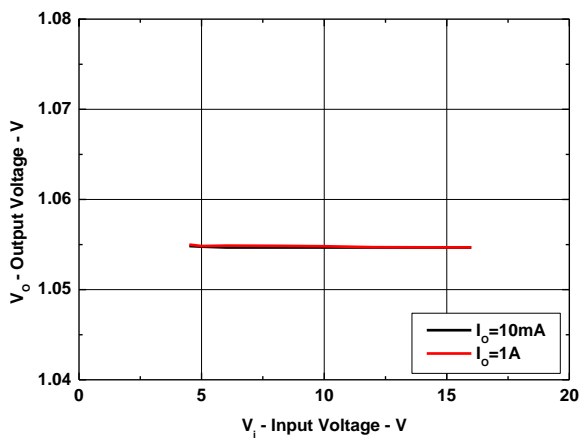

Fig. 5 Output Voltage vs. Input Voltage

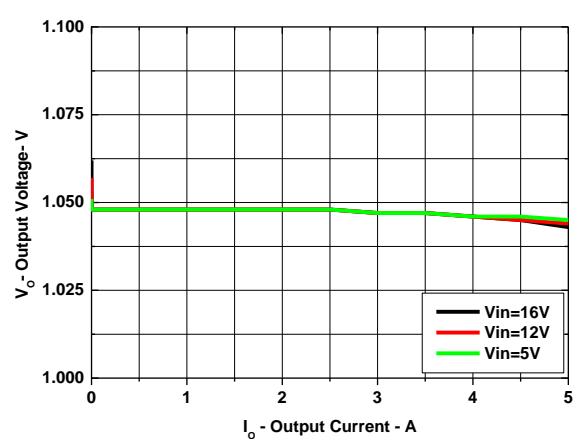

Fig. 6 Output Voltage vs. Output Current

■ TYPICAL PERFORMANCE CHARACTERISTICS (Continued)

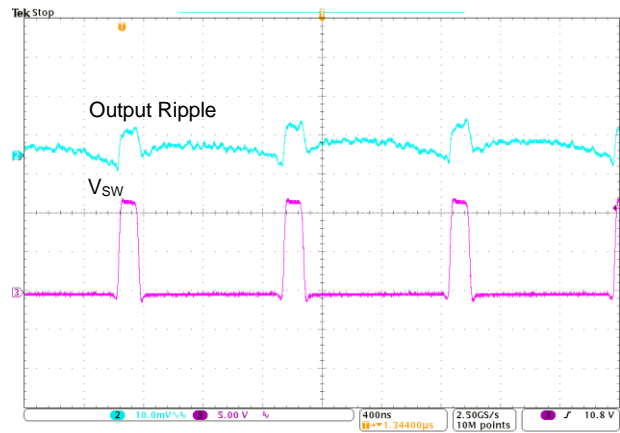
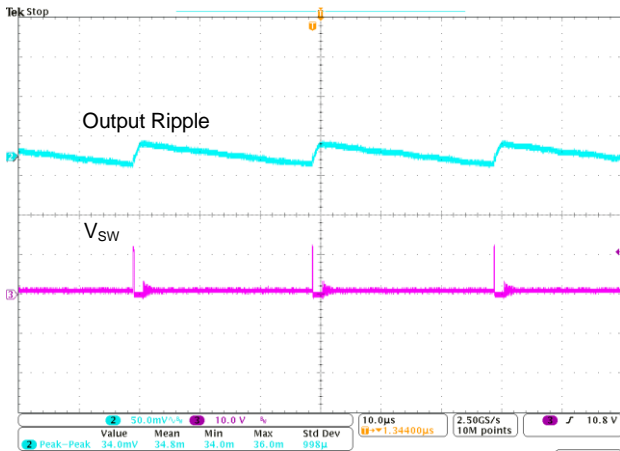

Fig. 7 Output Ripple at  $V_{IN}=12V$ ,  $V_{OUT}=1.05V$ ,  $I_{OUT}=30mA$  Fig. 8 Output Ripple at  $V_{IN}=12V$ ,  $V_{OUT}=1.05V$ ,  $I_{OUT}=5A$

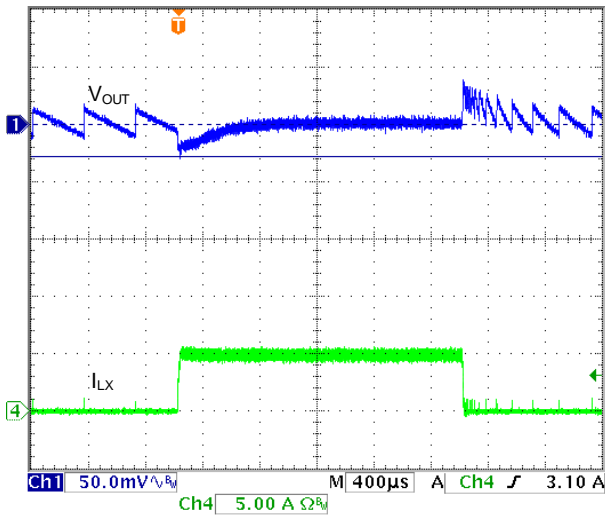

Fig. 9  $V_{IN}=12V$ ,  $V_{OUT}=1.05V$ ,  $I_{OUT}=0A$  to  $5A$

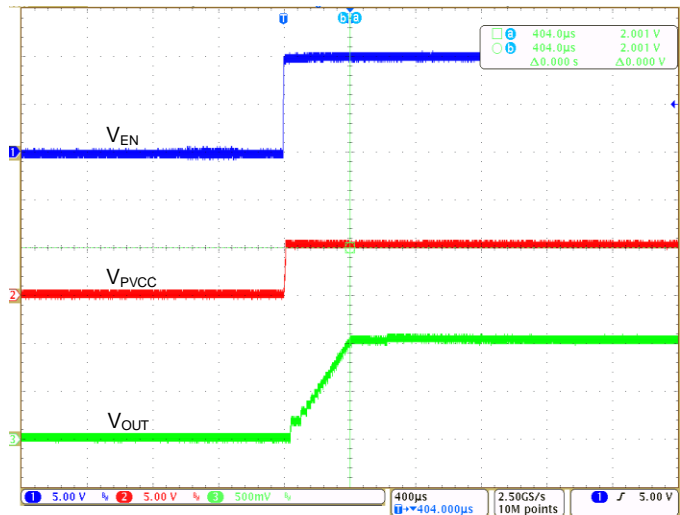
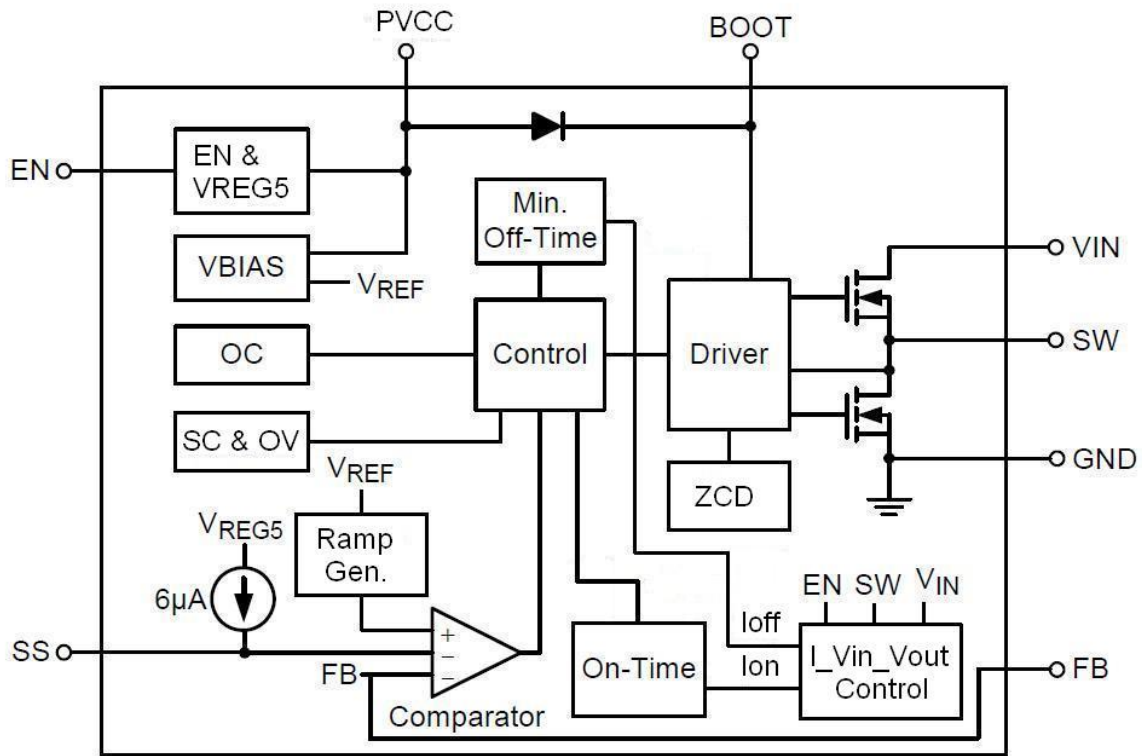

Fig. 10 Star\_Up at  $V_{IN}=12V$ ,  $V_{OUT}=1.05V$ ,  $I_{OUT}=0A$

**■ BLOCK DIAGRAM**

Functional Block Diagram of AIC2865

**■ PIN DESCRIPTIONS**

Pin No.	Pin Name	Pin Function
1	EN	Enable Input. EN is a digital input that turns the regulator on or off. Drive EN high to turn on the regulator. Drive it low to turn it off.
2	FB	Feedback Input. FB senses the output voltage to regulate that voltage. Drive feedback with a resistive voltage divider from the output voltage.
3	PVCC	Internal Regulator Output. Connect a capacitor to GND to stabilize output voltage.
4	SS	Soft Star Control Input. SS controls the soft star period. Connect a capacitor from SS to GND to set the soft-star period. A 3.9nF capacitor sets the soft-star period to about 0.5ms.
5	GND	Ground. Connect the exposed pad on backside to Pin 5.
6	SW	Power Switching Output. SW is the switching node that supplies power to the output. Connect the output LC filter from switch to the output load. Note that a capacitor is required from SW to BOOT to power the high-side switch.
7	BOOT	High Side Gate Drive Boost Input. BOOT supplies the drive for the high-side N-Channel MOSFET switch. Connect a 0.1μF or greater capacitor from BOOT to SW to power the high-side switch.
8	VIN	Power Input. VIN supplies power to the IC, as well as the step-down converter switches. Bypass VIN to GND with a suitably large capacitor to eliminate noise on the input to the IC.

## ■ APPLICATION INFORMATION

The AIC2865 is a constant on time control synchronous step down converter that can support the input voltage range from 4.5V to 16V and the output current can be up to 5A. During normal operation, the AIC2865 can regulate its output voltage through a feedback control circuit, which is composed of a comparator, a ramp generator, an on-time timer and several control signal generators. At the beginning of the switching cycle, the main power switch will be turned on and the synchronous power switch will be turned off through anti-short-through block. The main power switch will be turned off after the internal on-time timer expires. When the main power switch is turned off, the synchronous power switch will be turned on until feedback voltage signal is lower than the summing signal of reference voltage signal and ramp signal or the inductor current starts to reverse. The AIC2865 will enter discontinuous conduction mode (DCM) operation while working at light load conditions.

### Shutdown

By connecting the EN pin to GND, the AIC2865 can be shut down to reduce the supply current to 1 $\mu$ A (typical). At this operation mode, the output voltage of step-down converter is equal to 0V.

### Soft-Start

The AIC2865 provides the soft-start function. Initially, the voltage at SS pin is 0V. Then an internal current source of 6 $\mu$ A (typ.) charges an external soft-start capacitor. During the soft-start period, the voltage at SS pin will limit the feedback threshold voltage at FB pin. When the voltage at SS pin is higher than reference voltage, the feedback threshold voltage at FB pin reaches the desired value. The soft-start time can be calculated in accordance with the following

equation.

$$t_{SS} = C_{SS} \times \frac{V_{REF}}{6\mu A}$$

The soft-start capacitor is discharged to GND when the EN pin is connected to GND.

### Over Current Protection

The AIC2865 has a cycle-by-cycle current limit to protect the internal power switches. The cycle-by-cycle current limit protection directly limits inductor peak current. When the current limit protection is activated continually and output voltage becomes lower than the short circuit protection threshold, the AIC2865 will shut down the output power stage and then initiate the soft-start sequence. If the over current condition still exists and the output voltage still is lower than the short circuit protection threshold after the soft-start ends, the AIC2865 will repeat this operation mode until the over current condition is released.

### Short Circuit Protection

While the output is shorted to ground, the current limit protection function and the short circuit protection function are activated. In the short circuit protection mode, the AIC2865 will shut down the output power stage and then initiate the soft-start sequence. If the short circuit condition still exists after the soft-start ends, the AIC2865 will repeat this operation mode until the short circuit condition is released.

### Over Temperature Protection

The AIC2865 includes a thermal-limiting circuit, which is designed to protect the device from excessive temperature. When the junction temperature exceeds  $T_J=160^{\circ}\text{C}$ , the thermal-limiting circuit turns the internal power switches off and allows the IC to cool. The hysteresis of the over temperature protec-

tion is 40°C (typ).

### Inductor

The inductor selection depends on the current ripple of inductor, the input voltage and the output voltage.

$$L \geq \frac{V_{OUT}}{f_{SW} \cdot \Delta I_L} \left( 1 - \frac{V_{OUT}}{V_{IN}} \right)$$

Accepting a large current ripple of inductor allows the use of a smaller inductance. However, higher current ripple of inductor can cause higher output ripple voltage and large core loss. By setting an acceptable current ripple of inductor, a suitable inductance can be obtained from above equation.

In addition, it is important to ensure the inductor saturation current exceeds the peak value of inductor current in application to prevent core saturation. The peak value of inductor current can be calculated according to the following equation.

$$I_{PEAK} = I_{OUT(max)} + \frac{V_{OUT}}{2 \times f_{SW} \cdot L} \left( 1 - \frac{V_{OUT}}{V_{IN}} \right)$$

### Input Capacitor and Output Capacitor

To prevent the high input voltage ripple and noise resulted from high frequency switching, the use of low ESR ceramic capacitor for the maximum RMS current is recommended. The approximated RMS current of the input capacitor can be calculated according to the following equation.

$$I_{CINRMS} \approx \sqrt{I_{OUT(MAX)}^2 \times \frac{V_{OUT}(V_{IN} - V_{OUT})}{V_{IN}^2} + \frac{\Delta I_L^2}{12}}$$

The selection of output capacitor depends on the required output voltage ripple. The output voltage ripple can be expressed as:

$$\Delta V_{OUT} = \frac{\Delta I_L}{8 \times f_{OSC} \cdot C_{OUT}} + ESR \cdot \Delta I_L$$

For lower output voltage ripple, the use of low ESR

ceramic capacitor is recommended. The tantalum capacitor can also be used well, but its ESR is larger than that of ceramic capacitor.

When choosing the input and output ceramic capacitors, X5R and X7R types are recommended because they retain their capacitance over wider ranges of voltage and temperature than other types.

### Setting the Output Voltage

The output voltage is set using a resistive voltage divider connected from the output voltage to FB. The voltage divider divides the output voltage down to the feedback voltage by the ratio:

$$V_{FB} = V_{OUT} \frac{R_2}{R_1 + R_2}$$

Thus the output voltage is:

$$V_{OUT} = V_{REF} \times \frac{R_1 + R_2}{R_2}$$

For example, for a 3.3V output voltage and  $V_{REF}=0.765V$ ,  $R_2$  is 22kΩ, and  $R_1$  is 72.9kΩ.

### Layout Consideration

In order to ensure a proper operation of AIC2865, the following points should be managed comprehensively.

1. The input capacitor and  $V_{IN}$  should be placed as close as possible to each other to reduce the input voltage ripple and noise.
2. The output loop, which is consisted of the inductor, the internal power switch and the output capacitor, should be kept as small as possible.
3. The routes with large current should be kept short and wide.
4. Logically the large current on the converter should flow at the same direction.
5. In order to prevent the effect from noise, the IC's GND pin should be placed close to the ground of the input bypass capacitor.



6. The FB pin should be connected to the feedback resistors directly and the route should be away from the noise sources.

## APPLICATION EXAMPLES

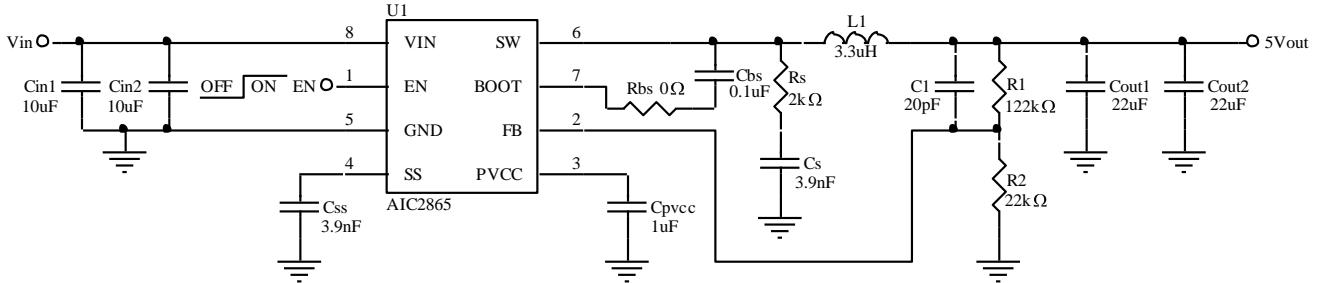
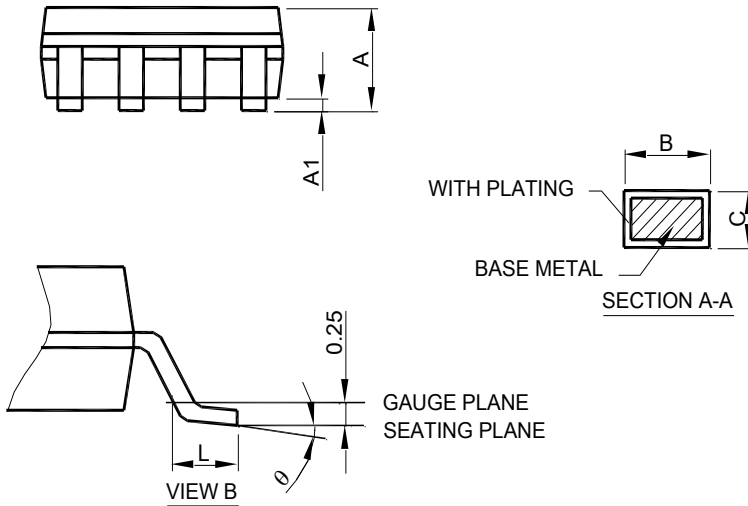
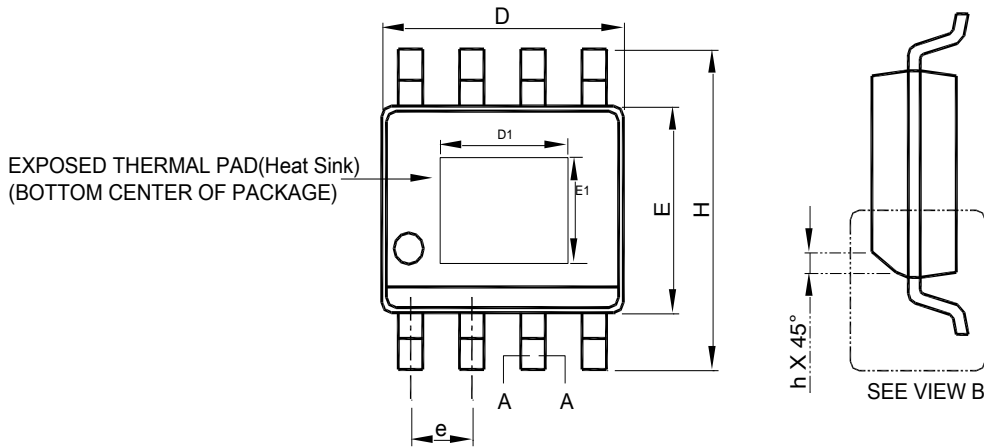

Fig. 11 Application Circuit for  $V_{IN} \geq 14V$  Condition

**PHYSICAL DIMENSIONS**

**SOP-8 Exposed Pad**



SYMBOL	SOP-8 Exposed Pad(Heat Sink)	
	MILLIMETERS	
	MIN.	MAX.
A	1.35	1.75
A1	0.00	0.15
B	0.31	0.51
C	0.17	0.25
D	4.80	5.00
D1	1.50	3.50
E	3.80	4.00
E1	1.0	2.55
e	1.27 BSC	
H	5.80	6.20
h	0.25	0.50
L	0.40	1.27
θ	0°	8°

- Note :
1. Refer to JEDEC MS-012E.
  2. Dimension "D" does not include mold flash, protrusions or gate burrs. Mold flash, protrusion or gate burrs shall not exceed 6 mil per side .
  3. Dimension "E" does not include inter-lead flash or protrusions.
  4. Controlling dimension is millimeter, converted inch dimensions are not necessarily exact.

**Note:**

Information provided by AIC is believed to be accurate and reliable. However, we cannot assume responsibility for use of any circuitry other than circuitry entirely embodied in an AIC product; nor for any infringement of patents or other rights of third parties that may result from its use. We reserve the right to change the circuitry and specifications without notice.

Life Support Policy: AIC does not authorize any AIC product for use in life support devices and/or systems. Life support devices or systems are devices or systems which, (i) are intended for surgical implant into the body or (ii) support or sustain life, and whose failure to perform, when properly used in accordance with instructions for use provided in the labeling, can be reasonably expected to result in a significant injury to the user.