

600kHz, 18V, 2A Synchronous Step-Down Converter

FEATURES

- High Efficiency: Up to 95%@5V
- 600kHz Frequency Operation
- 2.0A Output Current
- No Schottky Diode Required
- 3.5V to 18V Input Voltage Range
- 0.765V Reference
- Slope Compensated Current Mode Control for Excellent Line and Load Transient Response
- Integrated internal compensation
- Stable with Low ESR Ceramic Output Capacitors
- Over Current Protection with Hiccup-Mode
- Input overvoltage protection (OVP)
- Thermal Shutdown
- Inrush Current Limit and Soft Start
- Available in SOT23-6 Package

DESCRIPTION

The AIC2832B is a fully integrated, high-efficiency 2.0A synchronous rectified step-down converter. The AIC2832B operates at high efficiency over a wide output current load range.

This device offers two operation modes, PWM control and PFM Mode switching control, which allows a high efficiency over the wider range of the load.

The AIC2832B requires a minimum number of readily available standard external components and is available in a SOT23-6 package.

APPLICATIONS

- Distributed Power Systems
- Digital Set Top Boxes
- Flat Panel Television and Monitors
- Notebook computer
- Wireless and DSL Modems

APPLICATIONS CIRCUIT

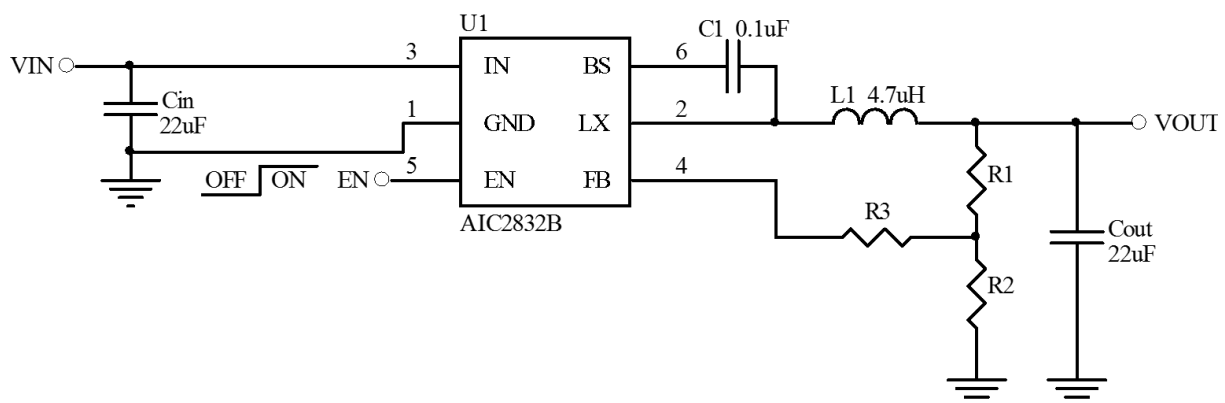

AIC2832B Typical Application Circuit

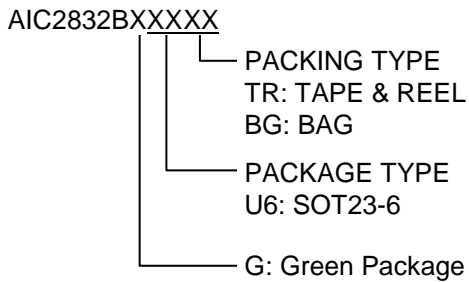
ORDERING INFORMATION

Example: AIC2832BGU6TR
 → SOT23-6 Green Package and Tape & Reel Packing Type

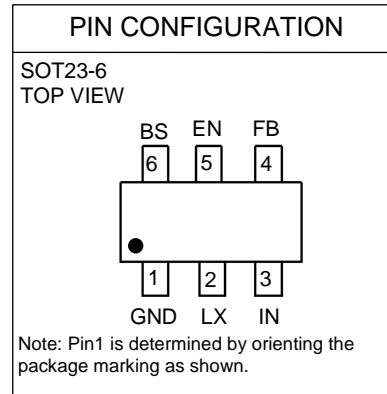

Top Mark: T35XXX (T35: Device Code, XXX: Inside Code)

Part No.	Marking
AIC2832BGU6	T35XXX

ABSOLUTE MAXIMUM RATINGS

IN Pin and EN Pin Voltage	- 0.3V to 20V
LX Pin Voltage	- 0.3V to 20V
LX Pin Voltage(10ns transient)	- 3.5V to 26V
BS Pin Voltage	(V _{LX} - 0.3V) to (V _{LX} + 6V)
FB Pin Voltage	- 0.3V to 6V
Junction Temperature ^(Note2)	160°C
Lead Temperature	260°C
Storage Temperature Range	- 65°C ~ 150°C
Operating Ambient Temperature Range	- 40°C ~ 85°C
Power Dissipation.....	600mW
(Assume no Ambient Airflow, no Heatsink)	

Absolute Maximum Ratings are those values beyond which the life of a device may be impaired.

■ ELECTRICAL CHARACTERISTICS
($V_{IN}=12V$, $V_{EN}=5V$, $T_A=25^{\circ}C$, unless otherwise specified.) (Note1)

PARAMETER	SYMBOL	CONDITIONS	MIN	TYP	MAX	UNITS
Input Voltage Range	V_{IN}		3.5		18	V
OVP Threshold	V_{OVP}			19		V
UVLO Threshold	V_{UVLO}		3.0			V
Supply Current in Operation		$V_{EN}=2.0V$, $V_{FB}=0.8V$		0.4	0.6	mA
Supply Current in Shutdown		$V_{EN}=0$		1		μA
Regulated Feedback Voltage	V_{FB}	$T_A = 25^{\circ}C$, $3.5V \leq V_{IN} \leq 18V$	0.75	0.765	0.78	V
High-Side Switch On-Resistance	$R_{DS(ON)1}$			120		m Ω
Low-Side Switch On-Resistance	$R_{DS(ON)2}$			70		m Ω
High-Side Switch Leakage Current		$V_{EN}=0V$, $V_{LX}=0V$		0	10	μA
Upper Switch Current Limit		Minimum Duty Cycle	2.5			A
Oscillation Frequency	f_{OSC}	$V_{FB}=0.765V$		600		kHz
Maximum Duty Cycle	D_{MAX}	$V_{FB}=0.765V$		95		%
EN Rising Threshold			1.15	1.30	1.45	V
EN Falling Threshold				1.28		V
Minimum On-Time	T_{ON}			100		ns
Thermal Shutdown	T_{SD}			160		$^{\circ}C$

Note 1: Specifications are production tested at $T_A=25^{\circ}C$. Specifications over the $-40^{\circ}C$ to $85^{\circ}C$ operating temperature range are assured by design, characterization and correlation with Statistical Quality Controls (SQC).

Note 2: T_J is calculated from the ambient temperature T_A and power dissipation P_D according to the following formula: $T_J = T_A + (P_D) \times (250^{\circ}C/W)$.

Note 3: Dynamic supply current is higher due to the gate charge being delivered at the switching frequency

TYPICAL PERFORMANCE CHARACTERISTICS

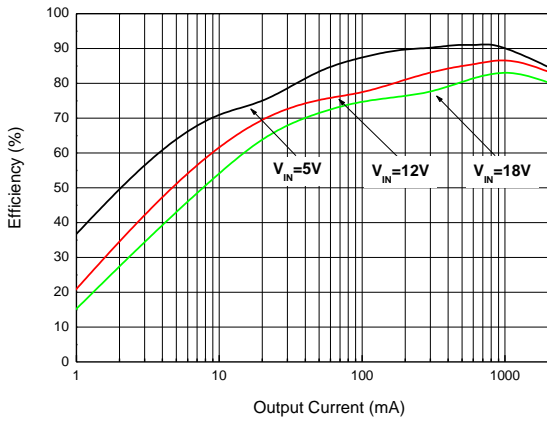

Fig. 1 Efficiency vs. Output Current ($V_{OUT}=1.8V$)

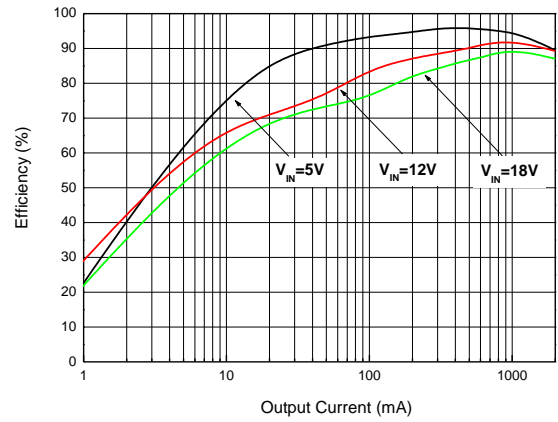

Fig. 2 Efficiency vs. Output Current ($V_{OUT}=3.3V$)

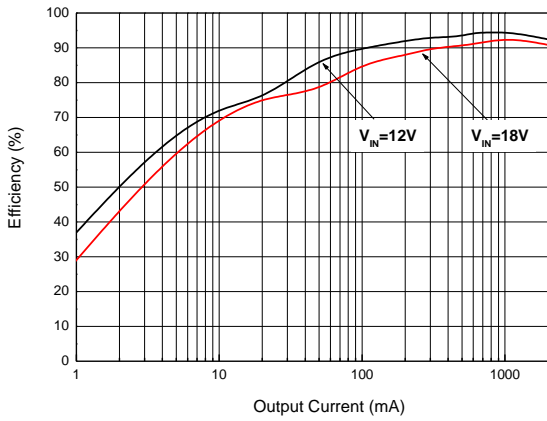

Fig. 3 Efficiency vs. Output Current ($V_{OUT}=5V$)

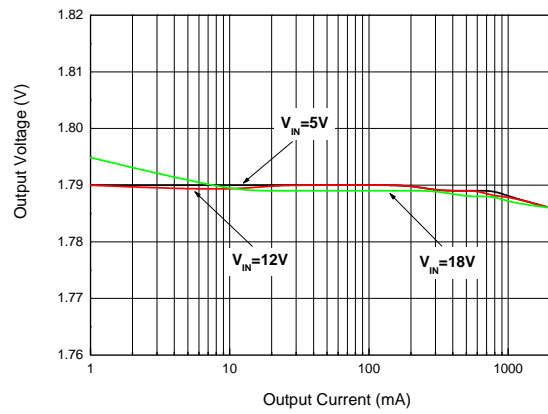

Fig. 4 Output Voltage vs. Output Current ($V_{OUT}=1.8V$)

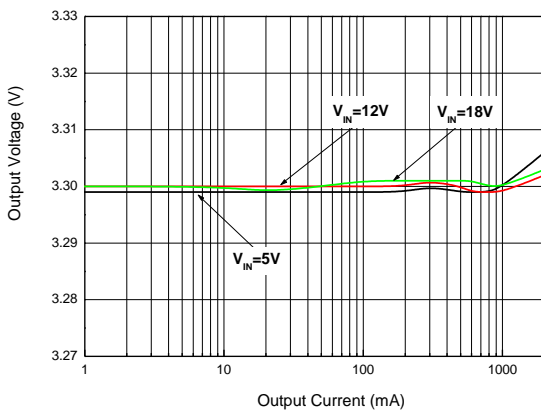

Fig. 5 Output Voltage vs. Output Current ($V_{OUT}=3.3V$)

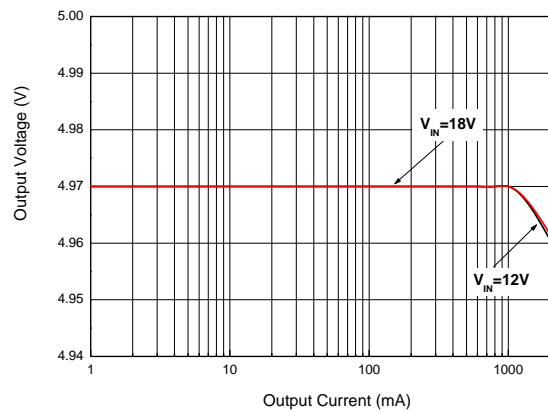

Fig. 6 Output Voltage vs. Output Current ($V_{OUT}=5V$)

TYPICAL PERFORMANCE CHARACTERISTICS (Continued)

 (CH1: V_{LX} , CH3: $V_{OUT(ac)}$, CH4: I_L)

 Fig. 7 Output Ripple ($V_{IN}=12V$, $V_{OUT}=1.8V$, $I_{OUT}=1mA$)

 (CH1: V_{LX} , CH3: $V_{OUT(ac)}$, CH4: I_L)

 Fig. 8 Output Ripple ($V_{IN}=12V$, $V_{OUT}=1.8V$, $I_{OUT}=2A$)

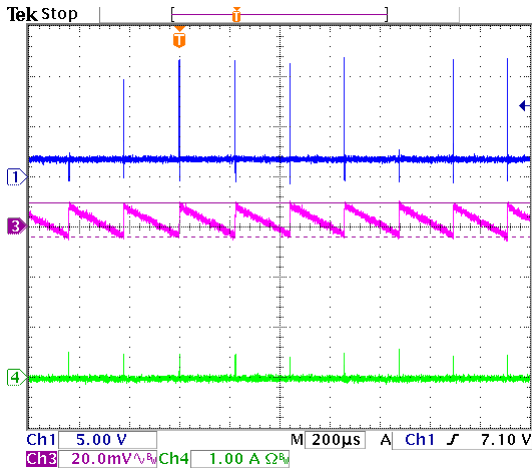
 (CH1: V_{IN} , CH2: V_{LX} , CH3: V_{OUT} , CH4: I_L)

 Fig. 9 V_{IN} Power On ($V_{IN}=12V$, $V_{OUT}=3.3V$, $I_{OUT}=0A$)

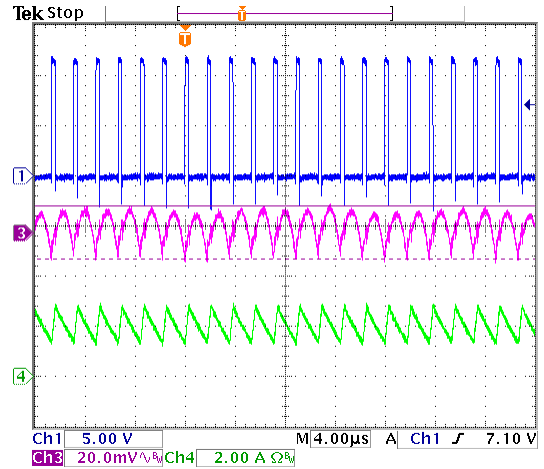
 (CH1: V_{IN} , CH2: V_{LX} , CH3: V_{OUT} , CH4: I_L)

 Fig. 10 V_{IN} Power On ($V_{IN}=12V$, $V_{OUT}=3.3V$, $I_{OUT}=2A$)

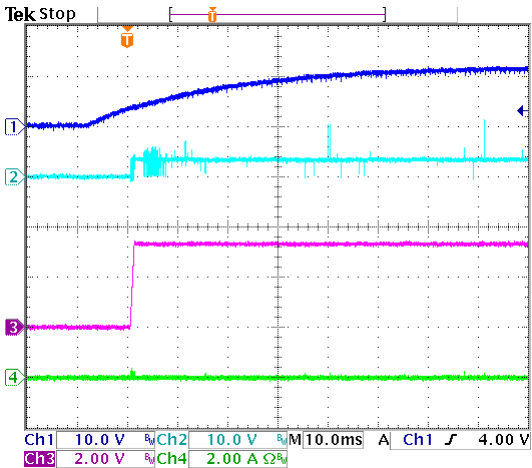
 (CH1: V_{EN} , CH2: V_{LX} , CH3: V_{OUT} , CH4: I_L)

 Fig. 11 Enable On ($V_{IN}=12V$, $V_{OUT}=3.3V$, $I_{OUT}=0A$)

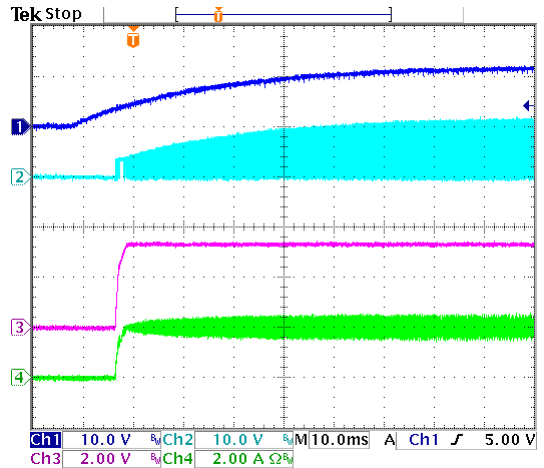
 (CH1: V_{EN} , CH2: V_{LX} , CH3: V_{OUT} , CH4: I_L)

 Fig. 12 Enable On ($V_{IN}=12V$, $V_{OUT}=3.3V$, $I_{OUT}=2A$)

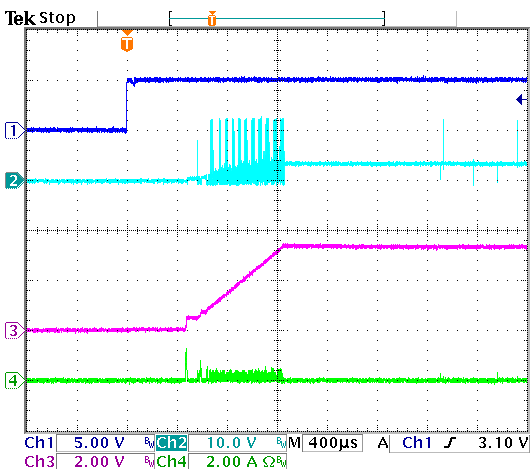
■ TYPICAL PERFORMANCE CHARACTERISTICS (Continued)

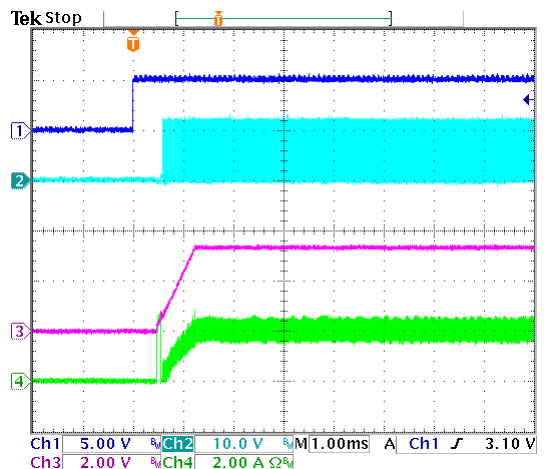
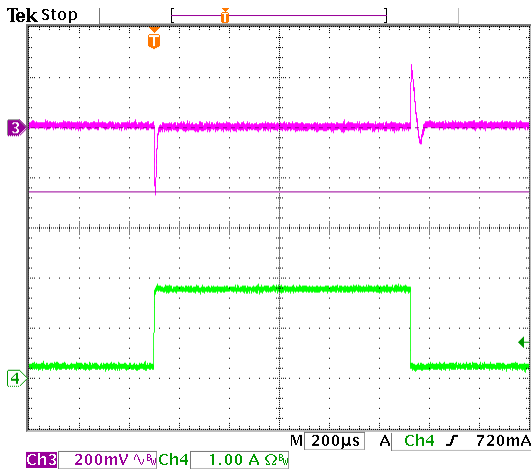
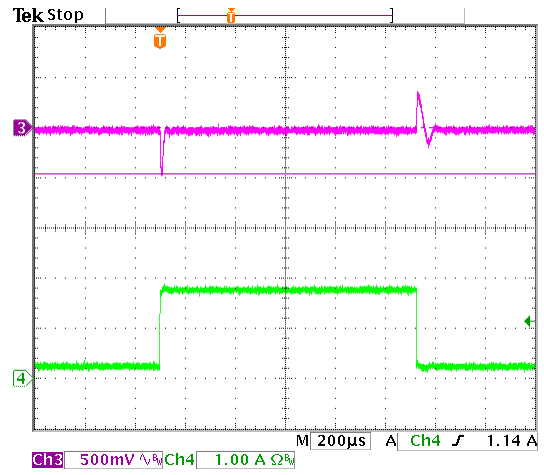

(CH3: $V_{OUT(ac)}$, CH4: I_{OUT})



(CH3: $V_{OUT(ac)}$, CH4: I_{OUT})

Fig. 13 Load Transient ($V_{IN}=12V$, $V_{OUT}=3.3V$, $I_O=0.2-1.8A$) Fig. 14 Load Transient ($V_{IN}=12V$, $V_{OUT}=5V$, $I_O=0.2-1.8A$)

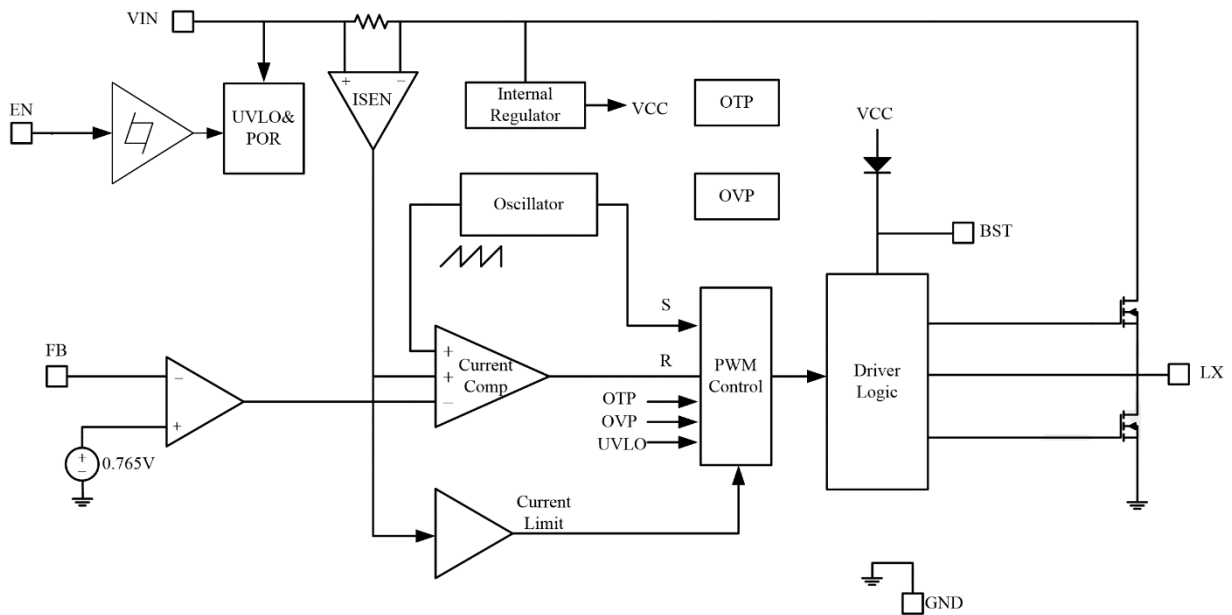
■ BLOCK DIAGRAM

Functional Block Diagram of AIC2832B

■ PIN DESCRIPTIONS

Pin No.	Pin Name	Pin Function
1	GND	Ground.
2	LX	Switching Pin.
3	IN	Power supply Pin.
4	FB	Adjustable version feedback input. Connect FB to the center point of the external resistor divider.
5	EN	Drive this pin to a logic-high to enable the IC. Drive to a logic-low to disable the IC and enter micro-power shutdown mode. Cannot floating.
6	BS	Bootstrap. A capacitor connected between LX and BS pins is required to form a floating supply across the high-side switch driver.

■ APPLICATION INFORMATION

Internal Regulator

The AIC2832B is a current mode step down DC/DC converter that provides excellent transient response with no extra external compensation components. This device contains an internal, low resistance, high voltage power MOSFET, and operates at a high 600kHz operating frequency to ensure a compact, high efficiency design with excellent AC and DC performance.

Error Amplifier

The error amplifier compares the FB pin voltage with the internal FB reference (VFB) and outputs a current proportional to the difference between the two. This output current is then used to charge or discharge the internal compensation network to form the COMP voltage, which is used to control the power MOSFET current. The optimized internal compensation network minimizes the external component counts and simplifies the control loop design.

Internal Soft-Start

The soft-start is implemented to prevent the converter output voltage from overshooting during startup. When the chip starts, the internal circuitry generates a soft-start voltage (SS) ramping up from 0V to 0.765V. When it is lower than the internal reference (REF), SS overrides REF so the error amplifier uses SS as the reference. When SS is higher than REF, REF regains control. The SS time is internally fixed to 1ms.

Over-Current-Protection and Hiccup

The AIC2832B has cycle-by-cycle over current limit when the inductor current peak value exceeds the set current limit threshold. Meanwhile, output voltage starts to drop until FB is below the Under-Voltage (UV) threshold, typically 30% below the reference. Once a UV is triggered, the AIC2832B enters hiccup

mode to periodically restart the part. This protection mode is especially useful when the output is dead-short to ground. The average short circuit current is greatly reduced to alleviate the thermal issue and to protect the regulator. The AIC2832B exits the hiccup mode once the over current condition is removed.

Startup and Shutdown

If both VIN and EN are higher than their appropriate thresholds, the chip starts. The reference block starts first, generating stable reference voltage and currents, and then the internal regulator is enabled. The regulator provides stable supply for the remaining circuitries. Three events can shut down the chip: EN low, VIN low and thermal shutdown. In the shutdown procedure, the signaling path is first blocked to avoid any fault triggering. The COMP voltage and the internal supply rail are then pulled down. The floating driver is not subject to this shutdown command.

Setting the Output Voltage

The external resistor divider is used to set the output voltage (see figure 15). The feedback resistor R₁ also sets the feedback loop bandwidth with the internal compensation capacitor. Choose R₁ to be around 10kΩ for optimal transient response. R₂ is then given by:

$$R_2 = \frac{R_1}{\frac{V_{out}}{V_{FB}} - 1}$$

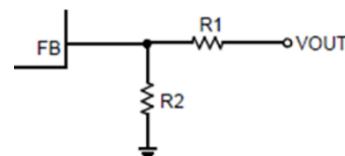

Fig. 15 External Resistor Divider

Inductor Selection

A 2.2μH to 6.8μH inductor with a DC current rating of at least 25% percent higher than the maximum load

current is recommended for most applications. For highest efficiency, the inductor DC resistance should be less than 15mΩ. For most designs, the inductance value can be derived from the following equation.

$$L = \frac{V_{out} \times (V_{in} - V_{out})}{V_{in} \times \Delta I_L \times f_{OSC}}$$

Where ΔI_L is the inductor ripple current. Choose inductor ripple current to be approximately 30% if the maximum load current 2A. The maximum inductor peak current is:

$$I_{L(MAX)} = I_{LOAD} + \frac{\Delta I_L}{2}$$

Under light load conditions below 100mA, larger inductance is recommended for improved efficiency.

Output Capacitor Selection

The output capacitor (C_2) is required to maintain the DC output voltage. Ceramic, tantalum, or low ESR electrolytic capacitors are recommended. Low ESR capacitors are preferred to keep the output voltage ripple low. The output voltage ripple can be estimated by:

$$\Delta V_{OUT} = \frac{V_{OUT}}{f_s \times L} \times \left[1 - \frac{V_{OUT}}{V_{IN}} \right] \times \left[R_{ESR} + \frac{1}{8 \times f_s \times C_2} \right]$$

Where L is the inductor value and R_{ESR} is the equivalent series resistance (ESR) value of the output capacitor. In the case of ceramic capacitors, the impedance at the switching frequency is dominated by the capacitance. The output voltage ripple is mainly caused by the capacitance. For simplification, the output voltage ripple can be estimated by:

$$\Delta V_{OUT} = \frac{V_{OUT}}{8 \times f_s^2 \times L \times C_2} \times \left[1 - \frac{V_{OUT}}{V_{IN}} \right]$$

In the case of tantalum or electrolytic capacitors, the

ESR dominates the impedance at the switching frequency. For simplification, the output ripple can be approximated to:

$$\Delta V_{OUT} = \frac{V_{OUT}}{f_s \times L} \times \left[1 - \frac{V_{OUT}}{V_{IN}} \right] \times R_{ESR}$$

The characteristics of the output capacitor also affect the stability of the regulation system. The AIC2832B can be optimized for a wide range of capacitance and ESR values.

Layout Consideration

PCB layout is very important to achieve stable operation. It is highly recommended to duplicate EVB layout for optimum performance. If change is necessary, please follow these guidelines.

- (1) Keep the path of switching current short and minimize the loop area formed by Input capacitor, high-side MOSFET and low-side MOSFET.
- (2) Bypass ceramic capacitors are suggested to be put close to the IN Pin.
- (3) Ensure all feedback connections are short and direct. Place the feedback resistors and compensation components as close to the chip as possible.
- (4) VOUT, LX away from sensitive analog areas such as FB.
- (5) Connect IN, LX, and especially GND respectively to a large copper area to cool the chip to improve thermal performance and long-term reliability.

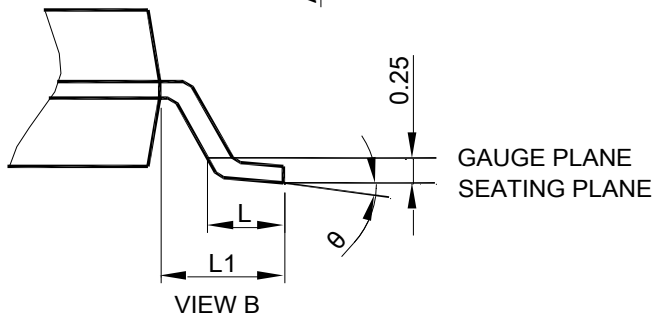
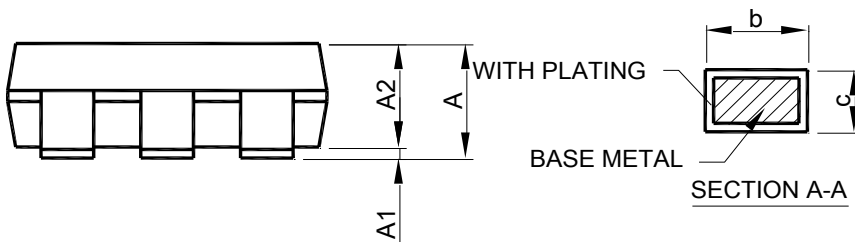
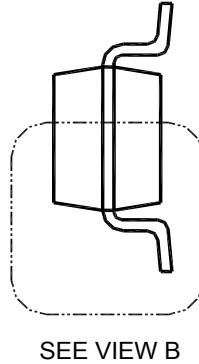
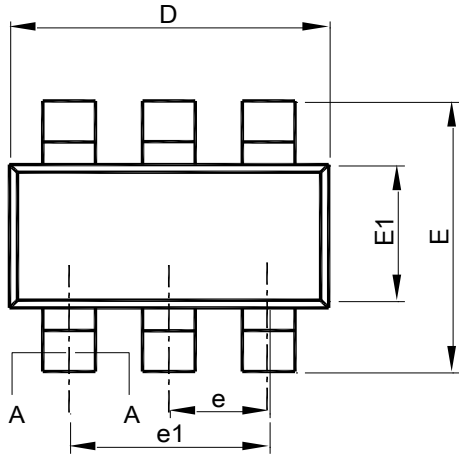
PHYSICAL DIMENSIONS
● SOT23-6

SYMBOL	SOT23-6	
	MILLIMETERS	
	MIN.	MAX.
A	0.95	1.45
A1	0.00	0.15
A2	0.90	1.30
b	0.30	0.50
c	0.08	0.22
D	2.80	3.00
E	2.60	3.00
E1	1.50	1.70
e	0.95 BSC	
e1	1.90 BSC	
L	0.30	0.60
L1	0.60 REF	
θ	0°	8°

- Note :
1. Refer to JEDEC MO-178AB.
 2. Dimension "D" does not include mold flash, protrusions or gate burrs. Mold flash, protrusion or gate burrs shall not exceed 10 mil per side.
 3. Dimension "E1" does not include inter-lead flash or protrusions.
 4. Controlling dimension is millimeter, converted inch dimensions are not necessarily exact.

Note:

Information provided by AIC is believed to be accurate and reliable. However, we cannot assume responsibility for use of any circuitry other than circuitry entirely embodied in an AIC product; nor for any infringement of patents or other rights of third parties that may result from its use. We reserve the right to change the circuitry and specifications without notice.

Life Support Policy: AIC does not authorize any AIC product for use in life support devices and/or systems. Life support devices or systems are devices or systems which, (i) are intended for surgical implant into the body or (ii) support or sustain life, and whose failure to perform, when properly used in accordance with instructions for use provided in the labeling, can be reasonably expected to result in a significant injury to the user.