

FEATURES

- 3A Continuous Output Current
- Wide 4.75V to 23V Operating Input Range
- Output Adjustable from 0.925V to 12V ($V_{REF}=0.925V$ Version)
- Output Adjustable from 0.8V to 12V ($V_{REF}=0.8V$ Version)
- Up to 95% Efficiency
- Low $R_{ds(on)}$ Internal Switches: 100m Ω and 85m Ω
- <3 μ A Supply Current in Shutdown Mode
- 340KHz/550KHz Frequency
- Programmable Soft Start
- Thermal Shutdown
- Cycle by Cycle Over Current Protection
- Under Voltage Lockout
- Short Circuit Protection
- Over Voltage Protection

APPLICATIONS

- Networking Systems
- Distributed Power Systems
- Pre-Regulator for Linear Regulators
- Set-top Box

DESCRIPTION

The AIC2823 is a monolithic synchronous step-down converter. The device can provide 3A output current from a 4.75V to 23V input supply.

The AIC2823's current mode architecture and external compensation allow the transient response to be optimized over a wide range of loads and capacitors. Current mode control also provides cycle-by-cycle current limit.

The AIC2823 provides over voltage protection and thermal shutdown. An adjustable soft-start prevents inrush current during turn on.

This device is available in a SOP-8 package, provides a very compact system solution with minimal external components and PCB area.

TYPICAL APPLICATIONS CIRCUIT

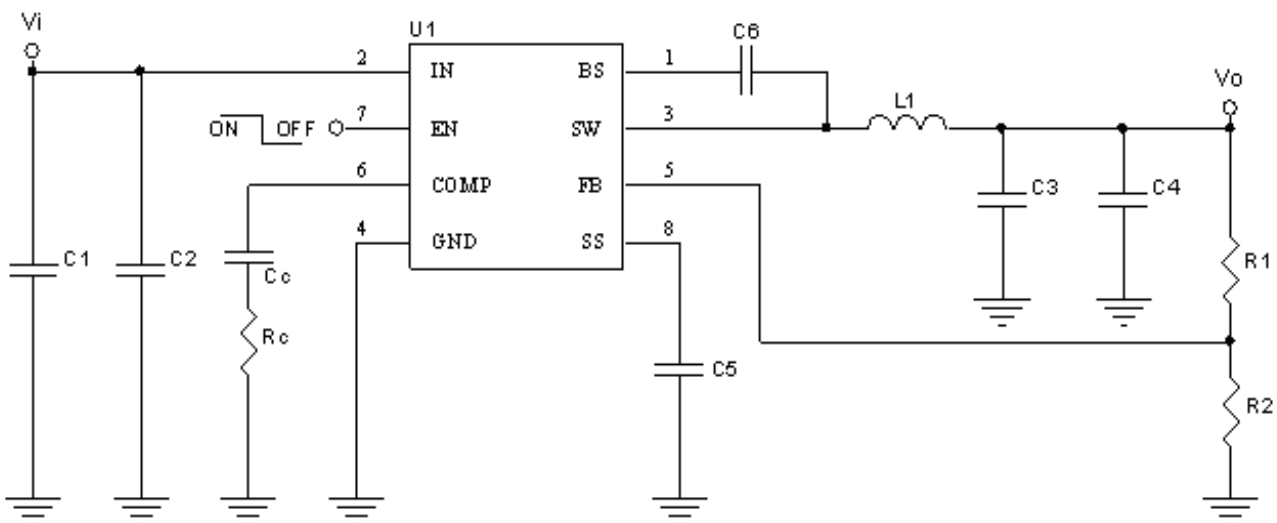

AIC2823 Typical Application Circuit

ORDERING INFORMATION

AIC2823-XXXXXX XX

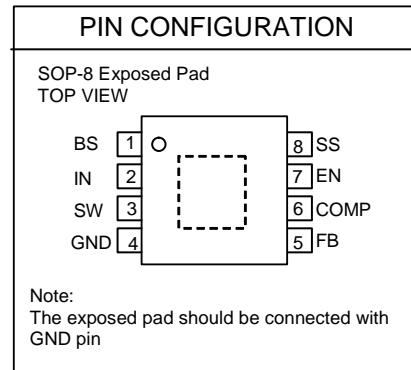
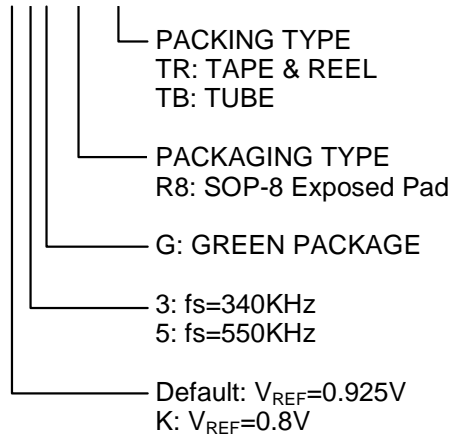

Example:

AIC2823-3GR8TR

→ $V_{REF}=0.925V$, fs=340KHz with GREEN SOP-8 Exposed Pad Package and TAPE & REEL Packing Type

AIC2823-K5GR8TR

→ $V_{REF}=0.8V$, fs=550KHz with GREEN SOP-8 Exposed Pad Package and TAPE & REEL Packing Type

ABSOLUTE MAXIMUM RATINGS

Input Voltage (V_{IN}).....	- 0.3V to 26V
SW Pin Voltage (V_{sw})	-1V to $V_{IN} + 0.3V$
BS Pin Voltage	$V_{sw} - 0.3V$ to $V_{sw} + 6V$
EN Pin Voltage.....	- 0.3V to V_{IN}
All Other Pins Voltage.....	- 0.3V to 6V
Operating Ambient Temperature Range T_A	- 40°C ~ 85°C
Operating Maximum Junction Temperature T_J	150°C
Storage Temperature Range T_{STG}	-65°C~150°C
Lead Temperature (Soldering 10 Sec.).....	260°C
Thermal Resistance Junction to Case SOP-8 Exposed Pad*	15°C/W
Thermal Resistance Junction to Ambient SOP-8 Exposed Pad*	60°C/W
(Assume no Ambient Airflow)	

Absolute Maximum Ratings are those values beyond which the life of a device may be impaired.

*The package is place on a two layers PCB with 2 ounces copper and 2 square inch, connected by 8 vias.

■ ELECTRICAL CHARACTERISTICS
(V_{IN}=12V, T_A=25°C, unless otherwise specified.) (Note1)

PARAMETER	SYMBOL	CONDITIONS	MIN	TYP	MAX	UNITS
Supply Voltage Range			4.75		23	V
Under Voltage Lockout Threshold		V _{IN} Rising	3.7	4.05		V
UVLO Hysteresis				210		mV
Shutdown Supply Current		V _{EN} = 0V		0.3	3	μA
Standby Current (Switching)		V _{EN} = 3.0V; SW = NC		0.7	1.5	mA
Reference Voltage (Default Version) (Note2)	V _{REF}		0.900	0.925	0.950	V
Reference Voltage (K Version) (Note2)	V _{REF}		0.779	0.8	0.821	V
Feedback Over Voltage Threshold		V _{FB} Rising		123		%
EN Shutdown Threshold Voltage		V _{EN} Rising	1.1	1.5	2.2	V
EN Shutdown Hysteresis				220		mV
High-Side Switch On-Resistance	R _{DS(ON)1}			100		mΩ
Low-Side Switch On-Resistance	R _{DS(ON)2}			85		mΩ
High-Side Switch Leakage Current		V _{EN} = 0V, V _{SW} = 0V		0	10	μA
High-Side Switch Current Limit		Peak Current	4.0	5.8		A
Oscillation Frequency (3 Version) (Note2)	fs		300	340	380	KHz
Oscillation Frequency (5 Version) (Note2)	fs		485	550	615	KHz
Short Circuit Oscillation Frequency		V _{FB} = 0V		110		KHz
Maximum Duty Cycle	D _{MAX}			90		%
Minimum On Time	T _{ON}			220		ns
Soft-Start Current		V _{SS} = 0V		6		μA
Soft-Start Period		V _{SS} = 0.1μF		15		ms
Thermal Shutdown		Trip Point		160		°C

Note 1: Specifications are production tested at T_A=25°C. Specifications over the -40°C to 85°C operating temperature range are assured by design, characterization and correlation with Statistical Quality Controls (SQC).

Note 2: Referring to the ordering information.

TYPICAL PERFORMANCE CHARACTERISTICS

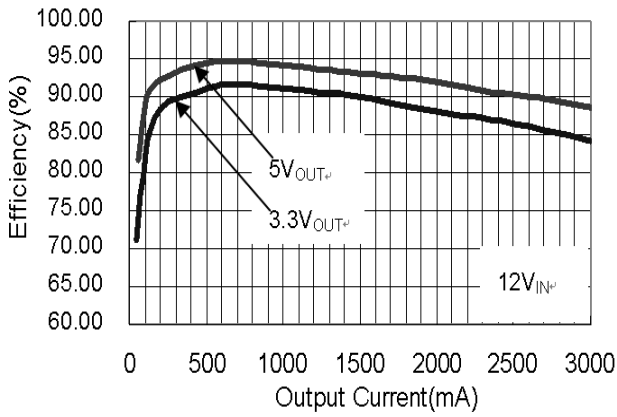

Fig. 1 Efficiency vs. Load Current

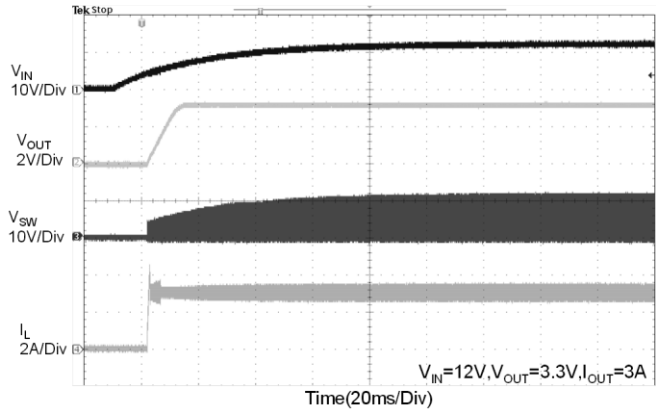

Fig. 2 Start-Up Waveform at $V_{OUT}=3.3V$, $I_{OUT}=3A$

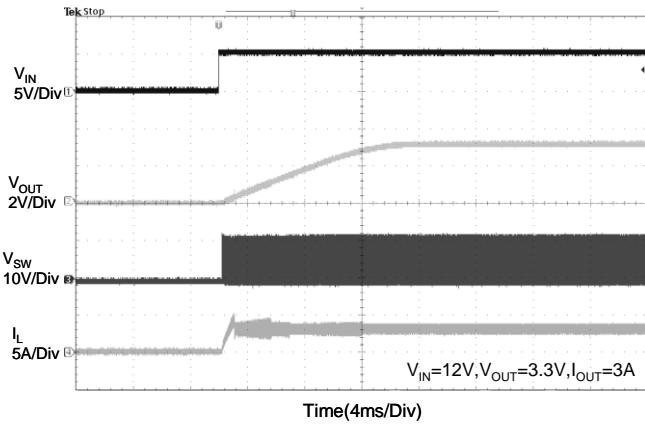

Fig. 3 Start-Up Waveform at $V_{OUT}=3.3V$, $I_{OUT}=3A$

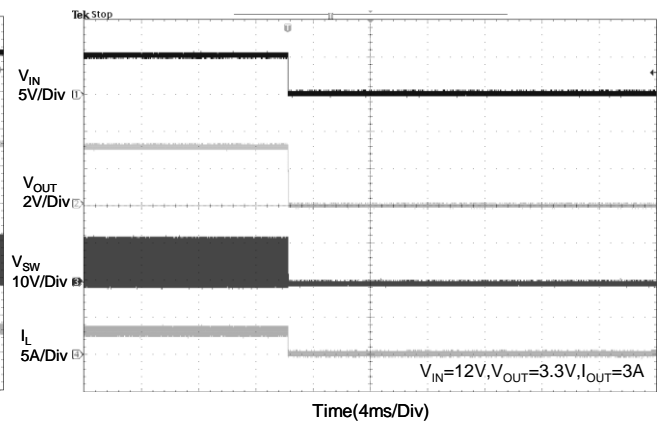

Fig. 4 Shutdown Waveform at $V_{OUT}=3.3V$, $I_{OUT}=3A$

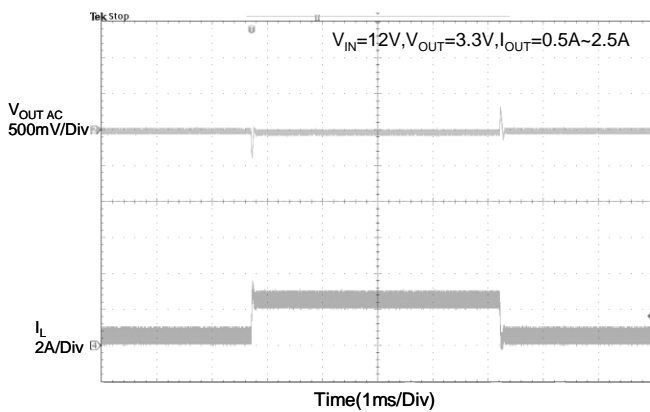

Fig. 5 Load Transient at $V_{OUT}=3.3V$, $I_{OUT}=0.5A$ to $2.5A$

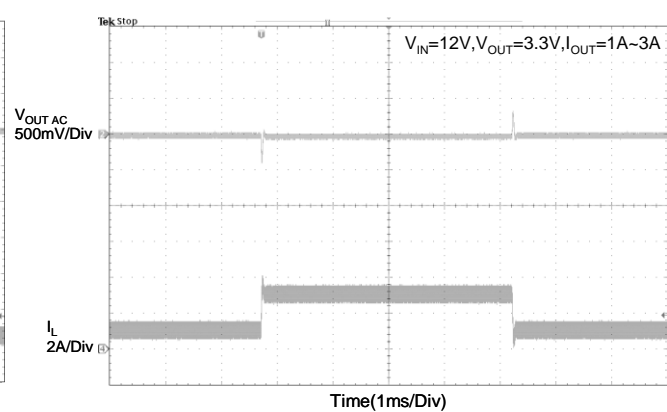

Fig. 6 Load Transient at $V_{OUT}=3.3V$, $I_{OUT}=1A$ to $3A$

TYPICAL PERFORMANCE CHARACTERISTICS (Continued)

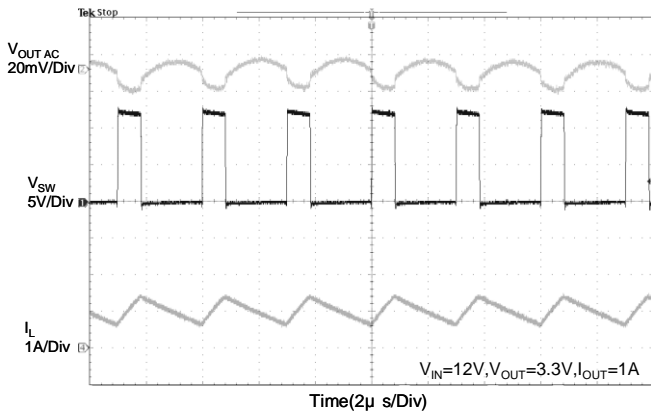

Fig. 7 Stability Waveform at $V_{OUT}=3.3V, I_{OUT}=1A$

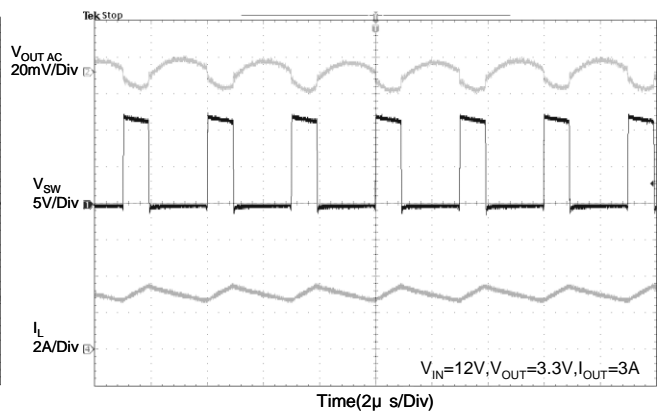
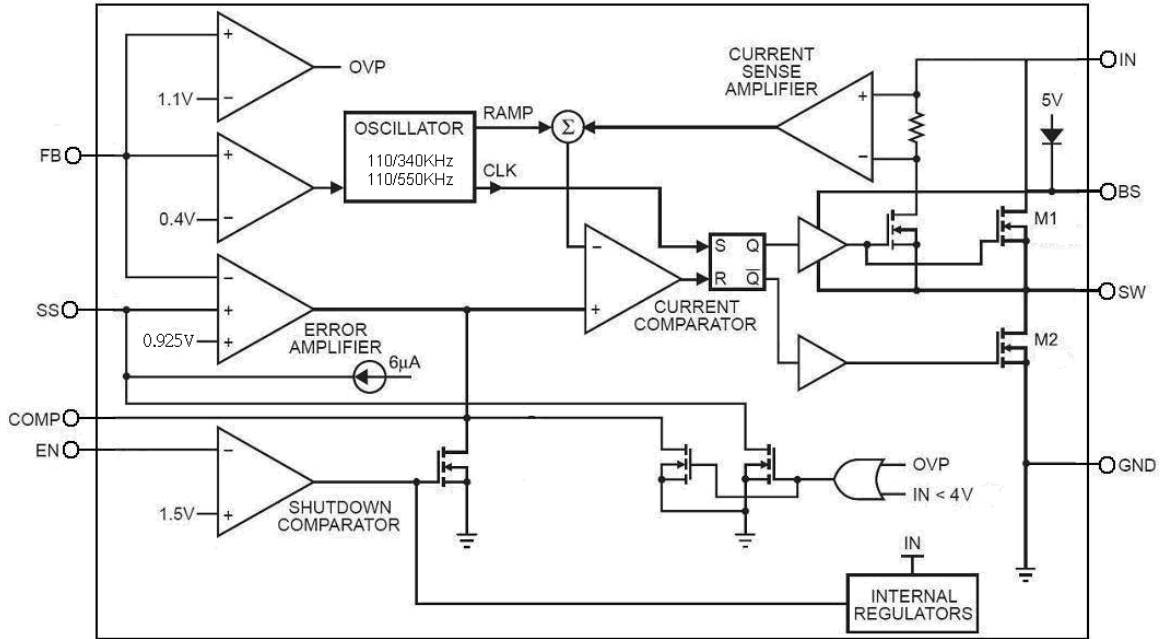
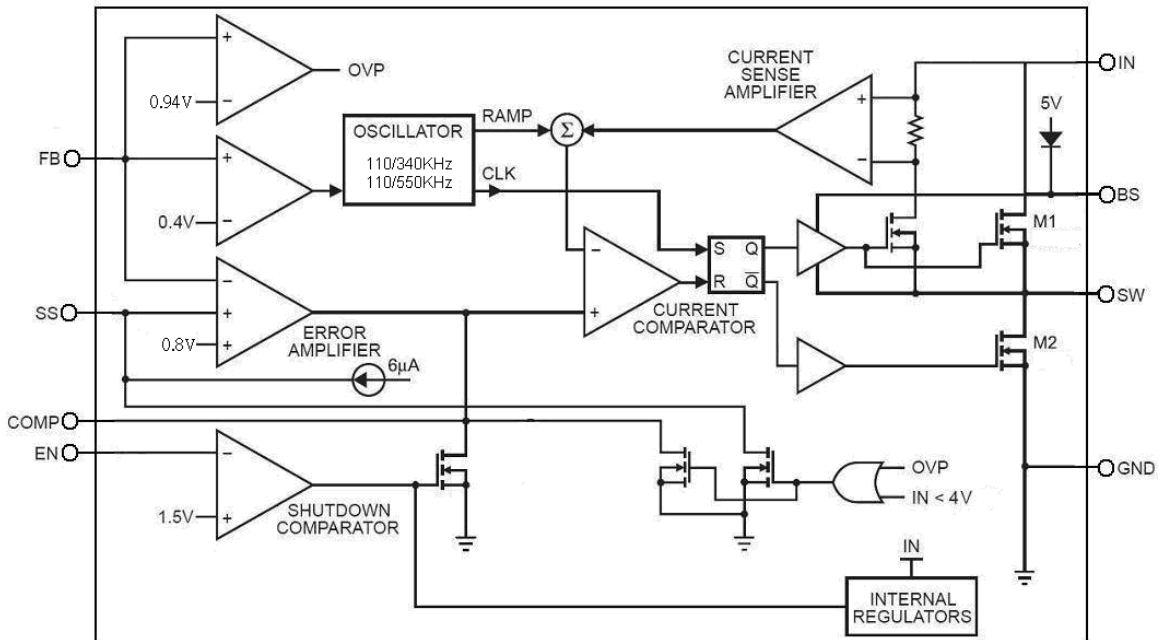

Fig. 8 Stability Waveform at $V_{OUT}=3.3V, I_{OUT}=3A$

■ BLOCK DIAGRAM

 Functional Block Diagram of AIC2823 ($V_{REF}=0.925V$ Version)

 Functional Block Diagram of AIC2823 ($V_{REF}=0.8V$ Version)

■ PIN DESCRIPTIONS

Pin No.	Pin Name	Pin Function
1	BS	High Side Gate Drive Boost Input. BS supplies the drive for the high-side N-Channel MOSFET switch. When the input voltage is lower than 16V, connecting a 10nF or greater capacitor from SW to BS to power the high-side switch. However, when the input voltage is higher than 16V, a 220nF or greater capacitor should be connected from SW to BS to power the high-side switch.
2	IN	Power Input. IN supplies power to the IC, as well as the step-down converter switches. By pass IN to GND with a suitably large capacitor to eliminate noise on the input to the IC.
3	SW	Power Switching Output. SW is the switching node that supplies power to the output. Connect the output LC filter from switch to the output load. Note that a capacitor is required from SW to BS to power the high-side switch.
4	GND	Ground. Connect the exposed pad on backside to Pin 4.
5	FB	Feedback Input. FB senses the output voltage to regulate that voltage. Drive feedback with a resistive voltage divider from the output voltage.
6	COMP	Compensation Node. COMP is used to compensate the regulation control loop. Connect a series RC network from COMP to GND to compensate the regulation control loop. In some cases, an additional capacitor from COMP to GND is required.
7	EN	Enable Input. EN is a digital input that turns the regulator on or off. Drive EN high to turn on the regulator. Drive it low to turn it off. For automatic start-up, attach to IN with a 100kΩ pull up resistor.
8	SS	Soft Star Control Input. SS controls the soft start period. Connect a capacitor from SS to GND to set the soft-start period. To disable the soft-start feature, leave the SS pin unconnected.

■ APPLICATION INFORMATIONS

The AIC2823 is a synchronous high voltage buck converter that can support the input voltage range from 4.75V to 23V and the output current can be up to 3A.

Setting the Output Voltage

The output voltage is set by using a resistive voltage divider connected from the output voltage to FB. The voltage divider divides the output voltage down to the feedback voltage by the ratio:

$$V_{FB} = V_{OUT} \times \frac{R2}{R1 + R2}$$

Thus the output voltage is:

$$V_{OUT} = V_{REF} \times \frac{R1 + R2}{R2}$$

For example, for a 3.3V output voltage and $V_{REF}=0.925V$, R2 is 10kΩ, and R1 is 25.6kΩ.

Inductor

The inductor selection depends on the current ripple of inductor, the input voltage and the output voltage.

$$L \geq \frac{V_{OUT}}{f_s \cdot \Delta I_L} \left(1 - \frac{V_{OUT}}{V_{IN}} \right)$$

Accepting a large current ripple of inductor allows the use of a smaller inductance. However, higher current ripple of inductor can cause higher output ripple voltage and large core loss. By setting an acceptable current ripple of inductor, a suitable inductance can be obtained from above equation.

In addition, it is important to ensure the inductor saturation current exceeds the peak value of inductor current in application to prevent core saturation. The peak value of inductor current can be calculated according to the following equation.

$$I_{PEAK} = I_{OUT(max)} + \frac{V_{OUT}}{2 \times f_s \cdot L} \left(1 - \frac{V_{OUT}}{V_{IN}} \right)$$

Soft-Start

The AIC2823 provides the soft-start function. Initially, the voltage at SS pin is 0V. Then an internal current source of 6μA (typ.) charges an external soft-start ca-

pacitor. During the soft-start period, the voltage at SS pin will limit the feedback threshold voltage at FB pin. When the voltage at SS pin is higher than reference voltage, the feedback threshold voltage at FB pin reaches the desired value. The soft-start time can be calculated in accordance with the following equation.

$$t_{SS} = C5 \times \frac{V_{REF}}{6\mu A}$$

The soft-start capacitor is discharged to GND when the EN pin is connected to GND.

Optional Schottky Diode

A Schottky diode with low forward drop voltage and fast reverse recovery is the ideal choice for better efficiency. The forward drop voltage of a Schottky diode will result in the conduction losses in the diode, and the diode capacitance (C_T or C_D) will cause the switching losses. Therefore, it is necessary to consider both forward voltage drop and diode capacitance for diode selection. In addition, the rating of selected Schottky diode should be able to handle the input voltage and the maximum peak diode current.

Input Capacitor and Output Capacitor

To prevent the high input voltage ripple and noise resulted from high frequency switching, the use of low ESR ceramic capacitor for the maximum RMS current is recommended. The approximated RMS current of the input capacitor can be calculated according to the following equation.

$$I_{CINRMS} \approx \sqrt{I_{OUT(MAX)}^2 \times \frac{V_{OUT}(V_{IN} - V_{OUT})}{V_{IN}^2} + \frac{\Delta I_L^2}{12}}$$

The selection of output capacitor depends on the required output voltage ripple. The output voltage ripple can be expressed as:

$$\Delta V_{OUT} = \frac{\Delta I_L}{8 \times f_s \times (C3 // C4)} + ESR \times \Delta I_L$$

For lower output voltage ripple, the use of low ESR ceramic capacitor is recommended. The tantalum capacitor can also be used well, but its ERS is larger

than that of ceramic capacitor.

When choosing the input and output ceramic capacitors, X5R and X7R types are recommended because they retain their capacitance over wider ranges of voltage and temperature than other types.

Loop Compensation

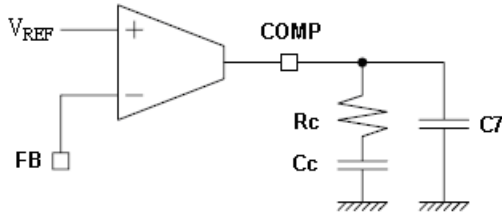

In order to avoid the poor output voltage ripple and low efficiency caused by instability, AIC2823 requires a proper external compensation network to compensate its feedback loop. In this external compensation network, the compensation resistor, R_C , and the compensation capacitor, C_C , are used to set the high-frequency integrator gain and the integrator zero. $C7$ is used to cancel the zero caused by the output capacitor and its ESR. While using the ceramic capacitor as the output capacitor, $C7$ can be omitted due to the small ESR.

The system has one pole of importance, due to the output capacitor, $C3//C4$ and the load resistor. This pole is located at:

$$F_{P1} = \frac{1}{2\pi \times (C3 // C4) \times R_{LOAD}}$$

The system has one zero of importance, due to the compensation capacitor, C_c and the compensation resistor, R_c . This zero is located at:

$$F_{Z1} = \frac{1}{2\pi \times C_c \times R_c}$$

The system may have another zero of importance, if the output capacitor has a large capacitance and/or a high ESR value. The zero, due to the ESR and capacitance of the output capacitor, is located at:

$$F_{ESR} = \frac{1}{2\pi \times (C3 // C4) \times R_{ESR}}$$

In this case, a third pole set by the compensation ca-

pacitor, $C7$ and the compensation resistor, R_c is used to compensate the effect of the ESR zero on the loop gain. This pole is located at:

$$F_{P2} = \frac{1}{2\pi \times C7 \times R_c}$$

✧ The values of the compensation components are given in the AIC2823 demo board user manual.

External Bootstrap Diode

When the input voltage is lower than 5.5V or the duty ratio is higher than 50%, an external bootstrap diode between the external BS voltage and the BS pin is recommended to be used for performance improvement. The external BS voltage must be lower than 5.5V. The external bootstrap diode can be the low cost 1N4148.

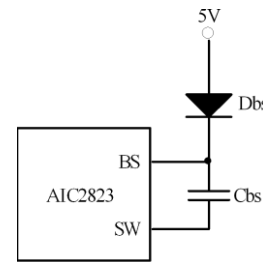

Fig. 9 Optional External Bootstrap Diode

Layout Consideration

In order to ensure a proper operation of AIC2823, the following points should be managed comprehensively.

1. The input capacitor and V_{IN} should be placed as close as possible to each other to reduce the input voltage ripple and noise.
2. The output loop, which is consisted of the inductor, the internal power switch and the output capacitor, should be kept as small as possible.
3. The routes with large current should be kept short and wide.
4. Logically the large current on the converter should flow at the same direction.
5. In order to prevent the effect from noise, the IC's GND pin should be placed close to the ground of the input bypass capacitor.
6. The FB pin should be connected to the feedback resistors directly and the route should be away from the noise sources.

■ PHYSICAL DIMENSIONS

● SOP-8 Exposed Pad

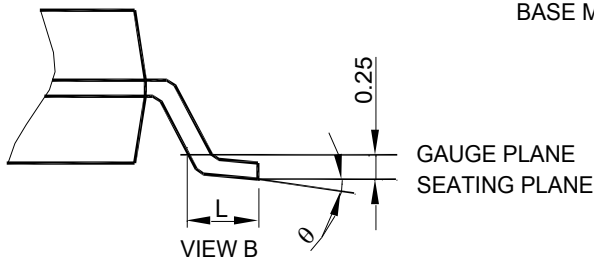
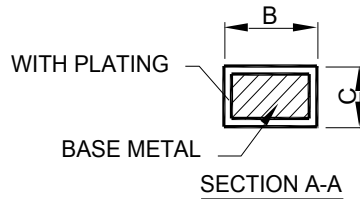
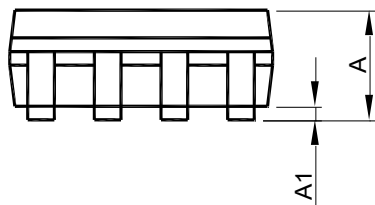
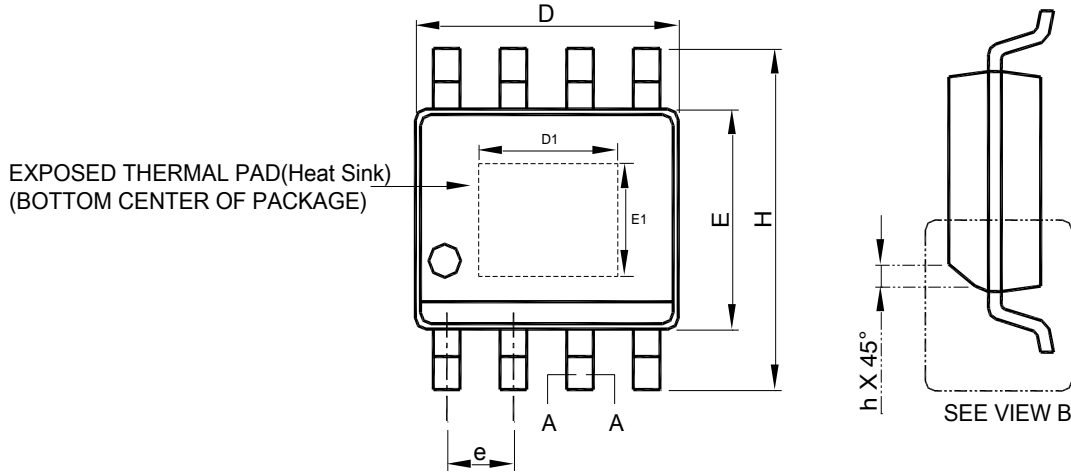

- Note :
1. Refer to JEDEC MS-012E.
 2. Dimension "D" does not include mold flash, protrusions or gate burrs. Mold flash, protrusion or gate burrs shall not exceed 6 mil per side .
 3. Dimension "E" does not include inter-lead flash or protrusions.
 4. Controlling dimension is millimeter, converted inch dimensions are not necessarily exact.

SYMBOL	SOP-8 Exposed Pad	
	MILLIMETERS	
	MIN.	MAX.
A	1.35	1.75
A1	0.00	0.15
B	0.31	0.51
C	0.17	0.25
D	4.80	5.00
D1	1.50	3.50
E	3.80	4.00
E1	1.0	2.55
e	1.27 BSC	
H	5.80	6.20
h	0.25	0.50
L	0.40	1.27
θ	0°	8°

Note:

Information provided by AIC is believed to be accurate and reliable. However, we cannot assume responsibility for use of any circuitry other than circuitry entirely embodied in an AIC product; nor for any infringement of patents or other rights of third parties that may result from its use. We reserve the right to change the circuitry and specifications without notice.

Life Support Policy: AIC does not authorize any AIC product for use in life support devices and/or systems. Life support devices or systems are devices or systems which, (I) are intended for surgical implant into the body or (ii) support or sustain life, and whose failure to perform, when properly used in accordance with instructions for use provided in the labeling, can be reasonably expected to result in a significant injury to the user.